

CONTENTS

X-RAY RADIATION PRECAUTION.....	1
SAFETY PRECAUTION.....	1
PRODUCT SAFETY NOTICE.....	2
GENERAL INSTRUCTION.....	2
ALIGNMENT ITEMS AND PROCEDURE.....	2
FACTORY ADJUSTMENT MODE.....	4
ADJUSTMENT METHOD.....	4
CHECKING POINTS.....	6
OUT-FACTORY MODE PRESET.....	6
POWER ADAPTABILITY CHECK.....	7
USA CHANNEL FREQUENCY TABLE (181 CH).....	15
WIRING DIAGRAM.....	17
BLOCK DIAGRAM.....	18
IC BLOCK DIAGRAM.....	19
SCHEMATIC DIAGRAM.....	27
ELECTRICAL PARTS LIST.....	29

CAUTION: THIS SERVICE MANUAL IS ONLY FOR PROFESSIONAL SERVICE PERSONNEL'S REFERENCE. BEFORE SERVICING THIS CHASSIS, PLEASE READ THE FOLLOWING NOTICE ITEMS.

1. SAFETY INSTRUCTION AND GENERAL INSTRUCTION

Before servicing and aligning this equipment, please read the following “**X-RAY RADIATION PRECAUTION**”, “**SAFETY PRECAUTION**” and “**PRODUCT SAFETY NOTICE**”.

1.1 X-RAY RADIATION PRECAUTION

- 1) Excessive high voltage can produce potentially hazardous X-RAY RADIATION. To avoid such hazards, the high voltage must not be above the specified limit. The normal value of the high voltage of this receiver is under 30 kV at zero beam current (minimum brightness) under DC135V main power(B+) , the high voltage must not, under any circumstances, exceed 32 kV.
- 2) Each time a receiver requires servicing, the high voltage should be checked following the HIGH VOLTAGE CHECK procedure in this manual. It is recommended the reading of the high voltage be recorded as a part of service record. It is important to use an accurate and reliable high voltage meter.
* When checking, main power (B+) should be kept at (135 V : for 24”, 100V : for 20”).
- 3) The primary source of X-RAY RADIATION in this TV receiver is the picture tube. For continuous X-RAY RADIATION protection, the replacement tube must be exactly the same type tube as specified in the parts list.
- 4) Some parts in this receiver have special safety-related characteristics for X-RAY RADIATION protection. For continuous safety, parts replacement should be undertaken only after referring to the PRODUCT SAFETY NOTICE below.

1.2 SAFETY PRECAUTION

WARNING:

Service should not be attempted by anyone unfamiliar with the necessary precaution on this receiver. The following are the necessary precautions to be observed before servicing this chassis.

- 1) Since the power supply circuit of this receiver is directly connected to the AC power line, an isolation transformer should be used during any dynamic service to avoid possible shock hazard.
- 2) Always discharge the picture tube anode to the CRT conductive coating before handling the picture tube. The picture tube is highly evacuated and if broken, glass fragments will be violently expelled. Use shatter proof goggles and keep picture tube away from the unprotected body while handling.
- 3) When replacing a chassis in the cabinet, always be certain that all the protective devices are put back in place, such as: non-metallic control knobs, insulating covers, shields, isolation resistor-capacitor network etc.
- 4) When replacing parts or circuit boards, disconnect the power cord.
- 5) When replacing a high wattage resistor (oxide metal film resistor) on the circuit board, keep the resistor 10mm (1/2in) away from circuit board.
- 6) Connection wires must be kept away from components with high voltage or high temperature.
- 7) If any fuse in this TV receiver is blown, replace it with the FUSE specified in the chassis parts list.

1.3 PRODUCT SAFETY NOTICE

Many electrical and mechanical parts in the chassis have special safety-related characteristics. These characteristics are often passed unnoticed by a visual inspection and the X-RAY RADIATION protection afforded by them cannot necessarily be obtained by using replacement components rated for higher wattage, etc. Replacement parts which have these special safety characteristics are identified in this manual and its supplement electrical components having such features are shaded on the schematic diagram and the parts list.

Before replacing any of these components, read the parts list in this manual carefully. The use of substitute replacement parts which do not have the same characteristics as specified in the parts list may create shock, fire, X-RAY RADIATION or other hazards.

1.4 General instruction

- 1.4.1 This chassis' EEPROM (N801 M24C08) should copy standard data first, if necessary, deal it with "factory adjustment". If directly use blank EEPROM, should first preset I²C data, then go on other common alignment. For factory adjustment method, refer to **The appendix: Factory adjustment mode**.
- 1.4.2 If without special indication, the alignment is conducted on the below condition:
 - a) AC power supply 120 V/60 Hz. (North America area) or others (depending on selling market).
 - b) The whole unit is preheated for more than 30 min.
- 1.4.3 There is built-in auto degaussing circuit, it will degauss automatically within 1second after turning on. And the auto degaussing circuit can effect only when turning off the set and waiting for at least 30min and then turning on.
- 1.4.4 If CRT is with magnetism and affects color purity and convergence, the internal degaussing can not degauss completely, can use degaussor to degauss externally. If color purity and convergence is still poor, then do color purity and convergence adjustment.

2 Alignment items and procedure

- 2.1 B+ voltage check
- 2.2 OSD character center adjustment
- 2.3 RFAGC voltage adjustment
- 2.4 Focus adjustment
- 2.5 Screen-grid voltage and white balance adjustment
- 2.6 SECAM colour adjustment
- 2.7 Horizontal, vertical scanning center adjustment
- 2.8 Horizontal, vertical scanning amplitude adjustment
- 2.9 Raster correction adjustment
- 2.10 The alignment flow chart see below figure.

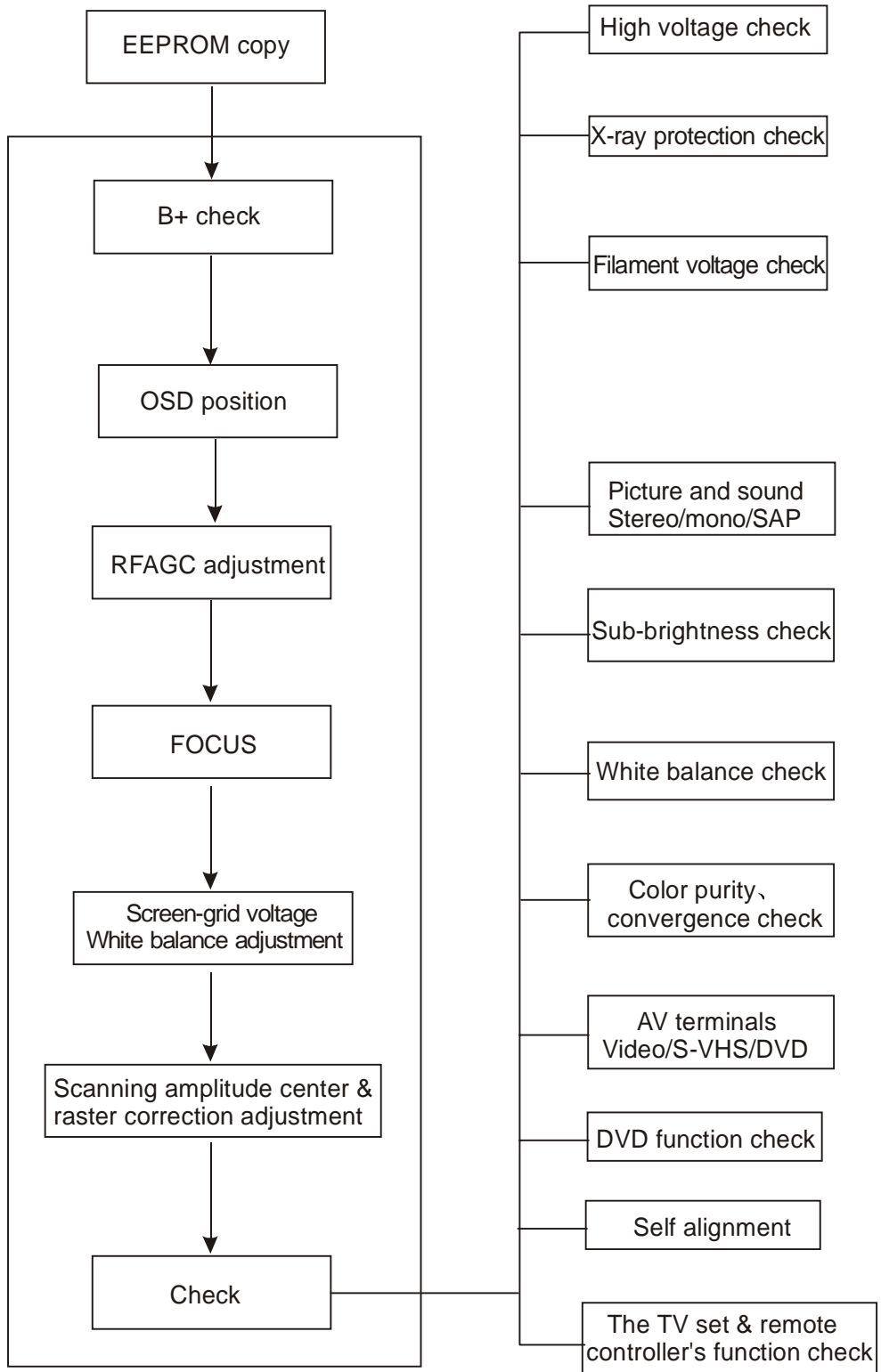

Figure 1: Alignment flow chart

3 Factory adjustment mode

3.1 Enter into factory adjustment menu

Press SLEEP→MUTE→DSP→MENU button on the remote controller in order (the period of two press should be less than 5 seconds), the screen will appear factory alignment menu.

3.2 Factory menu operation

Repeatedly press “MENU” button, then the menu will enter into PAGE 1→PAGE 2→PAGE 3→PAGE 4→PAGE 5 and recycle, press ▲ or ▼ button can select adjustment items upward or downward, and press ◀ or ▶ button to confirm or adjust the item’s value.

3.3 To exit the factory menu

Press “SLEEP” button to exit the factory adjustment menu.

4 Adjustment method

4.1 B+ voltage adjustment

a) Make sure the power supply is AC120 V/60 Hz(for America or Canada area).

b) Connect the digital voltmeter to B+ testing point, receive A7 signal, set the picture control to “STANDARD” status, adjust RP501 to make B+ voltage be (24”: 135V \pm 0.2 V , 20”: 100 V \pm 0.2 V) (just for pure flat CRT, as regards to other CRT, B+ value will be marked on the parts list.)

c) In STAND BY mode, the B+ voltage will be under 20V.

4.2 OSD position adjustment

Receive NTSC signal, change the factory adjustment menu page 3 OSD item’s value to make user’s menu be in screen’s center position.

4.3 AGC adjustment

a) Receive 60 dB split field (or grey-scale) signal.

b) Use oscilloscope or digital voltmeter to monitor tuner 1 pin’s voltage (RFAGC pin).

c) Select factory adjustment menu page 4 R-AGC item, making use of [←][→] button to increase the value from down to up until the voltage just reach 4.0 V, at this time picture noisy spots should disappear basically. Otherwise continue to fine tune R-AGC item.

d) Exit the factory menu.

4.4 Focus adjustment

4.4.1 Receive A12 signal, set picture mode to “STANDARD” status.

4.4.2 Adjust FBT FOCUS potentiometer to make screen’s B area’s focus optimum.

4.5 Screen-grid voltage,white balance adjustment

4.5.1 Receive A7 split field signal, set picture mode to “STANDARD” status.

4.5.2 Keep RCUT’s value, not change it (for example set it to 60), roughly adjust GCUT and BCUT value to make white balance basically normal.

4.5.3 Set colour,contrast to minimum, set brightness to 50. Use oscilloscope to monitor CRT board red gun waveform, adjust PAGE 4 BRTS value to make black level be 175 V.

4.5.4 Adjust SCREEN, accelerating electrode, potentiometer to make picture brighten 4 lattices.

4.5.5 Fine adjust white balance(colour temperature:12000K \pm 8MPCD X=0.270 \pm 0.008 Y=0.283 \pm

- 4.5.5 Fine adjust white balance (colour temperature: $12000\text{K} \pm 8\text{MPCD}$ $X=0.270 \pm 0.008$ $Y=0.283 \pm 0.008$).
- 4.5.6 Adjust PAGE 2 BRTN value to make colour ,brightness,contrast all be minimum, picture “white block” slightly lights up.
- 4.6 Horizontal,vertical scanning center adjustment
- 4.6.1 PAL (50 Hz) horizontal,vertical center adjustment
Receive G23 signal, set picture mode to “STANDARD” status, fine tune vertical center VP50, horizontal center HPOS, to make picture center be in accordance with screen center.
- 4.6.2 NTSC (60 Hz) H-center,V-center adjustment
Receive A6 signal, set picture mode to “STANDARD” status, adjust V-center VP60, H-center HPS, to make picture center be in accordance with screen center.
- 4.7 Vertical scanning amplitude adjustment
- 4.7.1 PAL (50 Hz) vertical amplitude adjustment
Receive D35 signal, set picture mode to “STANDARD” status, adjust vertical amplitude HIT, to make picture up/down overscanning be screen size’s 8%.
- 4.7.2 NTSC (60 Hz) vertical amplitude adjustment
Receive A12 signal, set picture mode to “STANDARD” status, adjust V-amplitude HITS, to make picture up/down overscanning be screen size’s 8%.
- 4.8 Raster correction adjustment,H-amplitude adjustment
- 4.8.1 PAL (50 Hz) raster correction adjustment ,H-amplitude adjustment.
Receive PAL white crosshatch signal, set picture mode to “STANDARD” status, adjust DPC to make raster distortion be in minimum, adjust WID to make picture left/right overscanning be screen size’s 8%.
- 4.8.2 NTSC (60 Hz) raster correction adjustment
Receive NTSC A21 signal, set picture mode to “STANDARD” status, adjust DPCS to make raster distortion minimum, adjust WIDS to make picture left/right overscanning be screen size’s 8%.
- 4.9 If scanning linearity distortion and raster geometrical distortion can not reach the requirements, and if necessary, can make use of factory adjustment menu to adjust the following items:
- | | |
|------|---|
| VLIN | V-linearity adjustment (PAL) |
| VLIS | V-linearity adjustment (NTSC) |
| VSC | Vertical S-correction adjustment (PAL) |
| VSS | Vertical S-correction adjustment (NTSC) |
| CNRT | Top corners’ correction |
| CNRB | Bottom corners’ correction |
| KEY | Trapezoid correction (PAL) |
| KEYS | Trapezoid correction (NTSC) |
- 4.10 Maximum sound output power
Receive single tone signal, set volume to maximum, the sound output power is $2 \times 3 \text{ W}(24'')$ and $2 \times 2.5 \text{ W}(20'')$. (can fine adjust factory menu V100)

5 Checking points

5.1 High voltage check

- 5.1.1 Connect high voltmeter to CRT second anode and GND.
- 5.1.2 Receive A7 signal, set picture mode to “STANDARD” status, measure the high voltage value, the reading should be $29\text{ kV}\pm 1\text{ kV}$.
- 5.1.3 When setting brightness and contrast to minimum(zero beam current), measure the high voltage value, the reading should not exceed 32 kV.

5.2 CRT filament voltage check

Receive A7 signal, set picture mode to “STANDARD” status, use effective value voltmeter to measure CRT filament voltage, the reading should be $(6.3\pm 0.3)\text{ Vrms}$.

5.3 X-ray protection check

- 5.3.1 Receive A7 signal, set picture mode to “STANDARD” status.
- 5.3.2 Short S301, X-ray protection circuit should effect.

5.4 Picture and sound check

- 5.4.1 Receive standard TV signal.
- 5.4.2 Make use of picture control buttons to check colour, contrast ,brightness,sharpness,tint’s control function.
- 5.4.3 Make use of sound control buttons to check sound control function.

5.5 Sub-brightness check.

Receive A7 signal, set colour, contrast , brightness all to 0,picture left one lattice slightly lights up.

5.6 This set can produce 14 kinds of testing signals by itself. In factory menu when select some adjustment item, every press of AV button for one time, it will produce one testing signal.

5.7 Colour purity and convergence check (in normal way)

5.8 AV terminal input/output check

5.9 Other control buttons on the set/remote controller function check

6 Out-factory mode preset

Press ”SHOP OUT” button, out-factory status will be preset to:

- | | | | |
|-----|-------------------|-----------------|-----|
| 6.1 | Picture menu: | Colour | 70 |
| | | Brightness | 70 |
| | | Contrast | 100 |
| | | Sharpness | 50 |
| | | Tint | 00 |
| | | Blue background | On |
| 6.2 | Volume preset to: | 30 | |
| 6.3 | Language menu: | ENGLISH | |
| 6.4 | Colour system : | AUTO | |
| 6.5 | NOISE REDUCE: | OFF | |

- 6.6 TV mode: Channel positionA2
- 6.7 SVM: MILD
- 6.8 V-CHIP PASSWORD: 0000
- 6.9 CHILD LOCK MENU
PASSWORD: 0000
- 6.10 SOUND MODE: NEWS
- 6.11 TV/CATV CHANNEL: Both set to ADD
- 6.12 CCD CHANNEL: Set to OFF
- 6.13 V-CHIP: Set all ratings and contents to IGNORE
- 6.14 V-CHIP BLOCK ON/OFF: Set to OFF

7 Power adaptability check

AC 120V/60Hz (for North America area. If have other special AC power supply requirements, then check with requirements).

APPENDIX 1 FACTORY ADJUSTMENT MENU

Page	Item NO.	OSD symbol	Preset	Adjustment item	Analogue setting	Input signal	Adjustment method
1	1	HPOS	0E	50Hz H-center	STANDARD	D35	To make picture horizontal center be in accordance with CRT center
	2	WID	10	50Hz H-size	STANDARD	D35	To make H-size meet standard
	3	HPS	03	60Hz H-center	STANDARD	A12	To make picture vertical center be in accordance with CRT center
	4	WIDS	01	60Hz H-size	STANDARD	A12	To make H-size meet standard
	5	HIT	35	50Hz V-size	STANDARD	D35	To make V-size meet standard
	6	VP50	06	50Hz V-center	STANDARD	D35	To make picture vertical center be in accordance with CRT center
	7	VLIN	0E	50Hz V-linearity	STANDARD	D35	To make upper/dower part crosshatch height be equal
	8	VSC	05	50Hz V S-correction	STANDARD	D35	To make upper/middle/lower part crosshatch height be in equal
	9	HEHT	04	Horizontal high voltage compensation	STANDARD	D35/A12	Fix
	10	VEHT	04	Vertical high voltage compensation	STANDARD	D35/A12	Fix
	11	TNTC	40	NTSC tint center value setting	Contrast 100 Tint 100 brightness70 color70	A7	Fix

	12	TNTN	00	NTSC tint minimum value setting	Contrast 100 Tint 0 brightness70 color 70	A7	fix
	13	SCOL	02	Sub-color adjustment	STANDARD	A7	Fix
	14	SCNT	07	Sub-brightness adjustment	STANDARD	Gray scale	Fix
	15	ASSH	00	Non-symmetry sharpness			Fix
1	16	ABL	23	ABL control (refer to appendix 2 for details)	SPORTS	A7	Fix
	17	VSS	02	60Hz V S-correction	STANDARD	A12	To make upper/middle/lower part crosshatch height be equal.
	18	VLIS	FE	60Hz V-linearity	STANDARD	A12	To make upper/lower part crosshatch height be equal
	19	VP60	02	60Hz V-center	STANDARD	A12	To make picture vertical center be in accordance with CRT center.
	20	HITS	03	60Hz V-size	STANDARD	A12	To make V-size meet standard
2	21	G CUT	66	Dark area white balance		Black/white balance signal or A7	To make picture dark area obtain standard white color.
	22	B CUT	6C				
	23	G DRV	45	Bright area white balance	SPORTS	Black/white balance signal or A7	To make picture bright area obtain standard white color.
	24	B DRV	4D				
	25	R CUT	60	Dark area white balance		Black/white balance signal or A7	To make picture dark area obtain standard white color.
	26	CNTX	3D	Contrast maximum value setting	SPORTS	Gray scale	Fix
	27	CNTC	36	Contrast center value setting	Contrast 50	Gray scale	Fix
	28	CNTN	22	Contrast minimum value setting	Contrast0 color 0 brightness50	Gray scale	Fix
	29	BRTX	3D	Brightness maximum value setting	Contrast50 color 0 brightness10 0	A7	Fix

	30	BRTC	36	Brightness center value setting	contrast0 color 0 brightness50	A7	Refer to adjustment methods
	31	OSD	17	OSD H-position setting		Any TV signal and display MENU screen	The character be in screen center.
	32	COLX	70	Color maximum value setting	SPORTS	A7	Fix
	33	COLC	3B	Color center value setting (NTSC)	STANDARD	A7	Fix
	34	COLP	20	Color center value setting (PAL)	STANDARD	AV (PAL)	Fix
	35	COLN	00	Color minimum value setting	Contrast 100 color 0 brightness50	A7	To make picture without color
	36	TNTX	6F	NTSC tint maximum value setting	Contrast 100 color 70 brightness70 tint 0	A7	Fix
	37	BRTN	20	Brightness minimum value setting	Contrast 0 color 0 brightness0	A7	Refer to adjustment method
	38	BRTS	24	Sub-brightness	contrast0 color 0 brightness50	A7	Refer to adjustment method
	39	V100	E0	VOL-100% volume setting	VOL-100%	Mono signal	Refer to adjustment method
	40	RAGC	2A	RF AGC	STANDARD	A7	Refer to adjustment method
3	41	DPC	0C	50Hz pincushion correction	STANDARD	D35	To correct picture E/W pincushion
	42	KEY	1B	50Hz pincushion correction	STANDARD	D35	To correct picture trapezoid
	43	DEF	01	Interlace scan setting 01			Fix
	44	FLG 0	52	Refer to Appendix 2 for details			Fix
	45	FLG 1	E5	Refer to Appendix 2 for details			Fix

	46	STBY	00	Refer to Appendix 2 for details			Fix
	47	TNCD	40	Tint center (DVD)			Fix
	48	VBLK	00	Refer to Appendix 2 for details			Fix
	49	MOD	03	Refer to Appendix 2 for details			Fix
	50	UCOM	80	Refer to Appendix 2 for details			Fix
3	51	MOD3	80	Refer to Appendix 2 for details			Fix
	52	OPT	17	Refer to Appendix 2 for details			Fix
	53	OPTM1	B2	Refer to Appendix 2 for details			Fix
	54	OPTM2	65	Refer to Appendix 2 for details			Fix
	55	TUNR	02	Tuner select			Fix
	56	CNRT	1D	Top edge/corner correction	STANDARD	D35/A12	To correct top edge and corner vertical line
	57	CNRT	15	Bottom edge/corner correction	STANDARD	D35/A12	To correct bottom edge and corner vertical line
	58	KEYS	01	60Hz trapezoid correction	STANDARD	A12	To correct picture trapezoid
	59	DPCS	00	60Hz pincushion correction	STANDARD	A12	To correct picture E/W pincushion
4	60	ST3	1F	Sub-sharpness center value when input NTSC3.58 TV signal	STANDARD	A12	Fix
	61	SV3	30	Sub-sharpness center value when input NTSC3.58 AV signal	STANDARD	AV-N3.58	Fix

	62	SV4	30	Sub-sharpness center value when input non NTSC3.58 AV signal.	STANDARD	AV-N4.43	Fix
	63	SVD	30	Sub-sharpness center value when in DVD input	STANDARD	DVD	Fix
	64	SHPX	1A	Sharpness maximum value setting	Sharpness 100	A12	Fix
	65	SHPN	1D	Sharpness minimum value setting	Sharpness 0	A12	Fix
	66	TXCX	1F	DVD sub-color maximum value	SPORTS	DVD	Fix
	67	RGCN	1F	DVD sub-color minimum value	STANDARD	DVD	Fix
	68	DCBS	22				Fix
	69	CLTM	0F	Refer to appendix 2 for details	STANDARD	A12	Fix
	70	CLVO	4F	Refer to appendix 2 for details	STANDARD	AV	Fix
	71	CLVD	58	Refer to appendix 2 for details	STANDARD	DVD	Fix
	72	CCD OSD	16	CCD H-position		Display CCD caption	CCD character be in screen center
	73	CCD OSDH	55	CCD OSD oscillating frequency			Fix
	74	HAFC	05	AFC gain			Fix
	75	VCEN	00	IC output vertical signal center			Fix
	76	NSHP	10	Noise reducing degree	STANDARD		Fix
	77	SYCT	08	(TEST)			Fix
	78	NOIS	01	(TEST)			Fix
	79	ONTM	00	POWER ON MUTE TIMER			Fix
5	80	V25	D0	Volume setting in VOL-25%	VOL-25	MONO signal	Fix

	81	V50	E0	Volume setting in VOL-50%	VOL-50	MONO signal	Fix
	82	OSDF	55	OSD oscillating frequency			Fix
	83	SUR 1	00	Surround sound data at Sound register 1			Fix
	84	BASC	30	Bass center value setting	VOL-50	Sound sweep frequency signal	Fix
	85	BASX	40	Bass maximum value setting	VOL-50		Fix
	86	TREC	39	Treble center value setting	VOL-50		Fix
	87	BALC	32	Balance center value setting	VOL-50		Fix
	88	WOFC	3D	Woofer center value setting			Fix
	89	BAS 1	32	Bass data at Sound Register 1	VOL-50		Fix
	90	BAS 2	5A	Bass data at Sound Register 2	VOL-50		Fix
	91	TRB 1	32	Treble data at Sound Register 1	VOL-50		Fix
5	92	TRB 2	28	Treble data at Sound Register2	VOL-50		Fix
	93	WCTL	30	Woofer control			Fix
	94	WON 1	00	“Woofer on” at Sound Register 1			Fix
<p>Note 1: firstly adjust PAL signal (D35), then adjust NTSC (A12), then recheck PAL signal (D35), please prior to guarantee NTSC raster.</p> <p>Note 2: when check PAL color, the inputting signal should be AV signal.</p>							

Appendix 2 factory adjustment menu remarks

FLG0	BIT0	Over Mod Switch	0:normal	1:POF over-modulation switch is connected
	BIT1	AFT window	0:out of AFT window	1:in the AFT window
	BIT2	Buzz reduction	0:Nyquist Buzz cancel on	1:off
	BIT3	Orthogonal detection gain	0:ont use	1:not use
	BIT4	Local SECAM	0:not use	1:not use

	BIT5	5.65MHz SIF	0:not use	1:not use
	BIT6	5.74MHz SIF	0:not use	1:not use
	BIT7	Frequency select no VCO adjustment	0:have VCO	1:without VCO
FLG1		CW on/off	0:off	1:on, CW ouput from IC pin26#
	BIT1	Y out on	0:not use	1:not use
	BIT2	MIZ gain	0:SIF 1MHz convert gain, low gain	1:high gain
	BIT5	C trap pass(test)	0:not use	1:not use
	BIT6	Detection NTSC3.58	0:not use	1:not use
	BIT7	teletext	0:not use	1:not use
MOD	BIT0	AKB CUT OFF sensitivity gain	00:X9.75	10:X10.25
	BIT1		01:X10	11:X10.50
	BIT2	Cut off range	0:-0.65 to +6.5	1:-0.65 to +0.85
UCOM	BIT0	inner ADC	00:GND	10:B out
	BIT1		01:R out	11:Monito RF AGC via ADC
	BIT2	rest pattern from ucom	0:normal	1:
	BIT3	use ucom sync switch	0:normal	1:use ucom sync
	BIT4	Sync to ucom	0:no use	1:no use
	BIT5	v-switch out ucom	0:no use	1:no use
	BIT7	OSD HD input polarity	0:no use	1:no use
MOD3	BIT4-0	VIDEO mute time	Mute time=data X 8ms	
	BIT7	VIDEO mute type	0:Y mute	1:RGB out cut off DC
OPT	BIT0	FBB-MUTE	0:	1:when blue background off, not do MUTE
	BIT1	FBB-EXMUTE	0:	1: when blue background off, not do EXT-MUTE
	BIT2	FYMUTE USE	0:	1:when switching channels, use Y-MUTE
	BIT3	Sound gain SW	0:50Hz	1:500mV RMS-25kHz/dev
	BIT4	Vertical frequency force	0:50Hz	1:60Hz
	BIT5	Sync detection	0:external	1:internal
	BIT7	Sync distinguish way	0:	1:gain noise detection
OPTM1	BIT0	FJP-SVM USE	0:SVM out	1:monitor out
	BIT1	AV select	0:AV1-AV2(DVD)-AV3	1:AV1-AV2-DVD
	BIT2	FJP-GAME	0:without game	1:have game
	BIT3	On-timer indication	0:low level, on-timer on	1:high level, on-timer on
	BIT6	FJP-M-PAL	0:others	1:only PAL-M
	BIT7	FJP-stereo	0:without stereo	1:have stereo
OPTM2	BIT0	FJP-Y.U.V	0:without Y.U.V	1:have Y.U.V
	BIT1	FJP-language	0:English/French/Spanish	1:English/Tradtional Chinese
	BIT2	F52797-VAMP	0:no gain	1:6dB gain
	BIT4	FJP-display button	0;timer display OSD	1:always display
	BIT5	FJP-woofer	0:without woofer	1:have woofer
	BIT6	FJP-AUTO	0:AUTO2(35N,M-PAL,N-PAL)	1:AUTO1(44P,35N,44N)

CLTM (in TV mode)	BIT0	Y delay (in TV mode)	000:-40ns	100:120ns
	BIT1		001:0	101:160ns
	BIT2		010:40ns 011:80ns	110:200ns 111:240ns
	BIT3	NTSC matrix	00:NTSC1(93°)	10,11 for DVD
	BIT4		01:NTSC2(108°)	
	BIT5	C-GAMMA	0:Chroma γ correction off	1:Chroma correction on
	BIT6	Color kill off	0:normal	1:color killer always off
	BIT7	P/N ID	0:P/N color killing sensitivity 1.2/1.5mVp-p	1:6.6/6.4mVp-p
CLVO (in AV mode)	BIT0	Y delay (in TV mode)	000:-40ns	100:120ns
	BIT1		001:0	101:160ns
	BIT2		010:40ns 011:80ns	110:200ns 111:240ns
	BIT3	NTSC matrix	00:NTSC1(93°)	10,11 for DVD
	BIT4		01:NTSC2(108°)	
	BIT5	C-GAMMA	0:Chroma γ correction off	1:Chroma γ correction on
	BIT6	Color kill off	0:normal	1:color killer always off
	BIT7	P/N ID	0:P/N color killing sensitivity 1.2/1.5mVp-p	1:6.6/6.4mVp-p
CLVD (in DVD mode)	BIT0	Y delay (in TV mode)	000:-40ns	100:120ns
	BIT1		001:0	101:160ns
	BIT2		010:40ns 011:80ns	110:200ns 111:240ns
	BIT3	NTSC matrix	00:NTSC1(93°)	10,11 for DVD
	BIT4		01:NTSC2(108°)	
	BIT5	C-GAMMA	0:Chroma γ correction off	1:Chroma γ correction on
	BIT6	Color kill off	0:normal	1:color killer always off
	BIT7	P/N ID	0:P/N color killing sensitivity 1.2/1.5mVp-p	1:6.6/6.4mVp-p
NDHP	When NOISE REDUCE ON, sharpness register' s content = OSD sharpness value-NSHP value			

USA CHANNEL FREQUENCY TABLE (181 CH)

P IF=45.75 MHz

C IF=42.17MHz

S IF=41.25MHz

UNIT: MHz

BAND	CHANNEL	P CARRIER	S CARRIER	LOCAL	BAND	CHANNEL	P CARRIER	S CARRIER	LOCAL
VHF Low	2	55.25	59.75	101	UHF	W+11	361.25	365.75	407
	3	61.25	65.75	107		W+12	367.25	371.75	413
	4	67.25	71.75	113		W+13	373.25	377.75	419
	5	77.25	81.75	123		W+14	379.25	383.75	425
	6	83.25	87.75	129		W+15	385.25	389.75	431
	A-6	85.25	89.75	131		W+16	391.25	395.75	437
	A-5	91.25	95.75	137		W+17	397.25	401.75	443
	A-4	97.25	101.75	143		W+18	403.25	407.75	449
	A-3	103.25	107.75	149		W+19	409.25	413.75	455
	A-2	109.25	113.75	155		W+20	415.25	419.75	461
	A-1	115.25	119.75	161		W+21	421.25	425.75	467
	A	121.25	125.75	167		W+22	427.25	431.75	473
	B	127.25	131.75	173		W+23	433.25	437.75	479
VHF High	C	133.25	137.75	179		W+24	439.25	443.75	485
	D	139.25	143.75	185		W+25	445.25	449.75	491
	E	145.25	149.75	191		W+26	451.25	455.75	497
	F	151.25	155.75	197		W+27	457.25	461.75	503
	G	157.25	161.75	203		W+28	463.25	467.75	509
	H	163.25	167.75	209		W+29	469.25	473.75	515
	I	169.25	173.75	215		14	471.25	475.75	517
	7	175.25	179.75	221		15	477.25	481.75	523
	8	181.25	185.75	227		16	483.25	487.75	529
	9	187.25	191.75	233		17	489.25	493.75	535
	10	193.25	197.75	239		18	495.25	499.75	541
	11	199.25	203.75	245		19	501.25	505.75	547
	12	205.25	209.75	251		20	507.25	511.75	553
	13	211.25	215.75	257		21	513.25	517.75	559
	J	217.25	221.75	263		22	519.25	523.75	565
	K	223.25	227.75	269		23	525.25	529.75	571
	L	229.25	233.75	275	24	531.25	535.75	577	
	M	235.25	239.75	281	25	537.25	541.75	583	
	N	241.25	245.75	287	26	543.25	547.75	589	
	O	247.25	251.75	293	27	549.25	553.75	595	
	P	253.25	257.75	299	28	555.25	559.75	601	
	Q	259.25	263.75	305	29	561.25	565.75	607	
	R	265.25	269.75	311	30	567.25	571.75	613	
	S	271.25	275.75	317	31	573.25	577.75	619	
	T	277.25	281.75	323	32	579.25	583.75	625	
	U	283.25	287.75	329	33	585.25	589.75	631	
	V	289.25	293.75	335	34	591.25	595.75	637	
	W	295.25	299.75	341	35	597.25	601.75	643	
	W+1	301.25	305.75	347	36	603.25	607.75	649	
	W+2	307.25	311.75	353	37	609.25	613.75	655	
	W+3	313.25	317.75	359	38	615.25	619.75	661	
	W+4	319.25	323.75	365	39	621.25	625.75	667	
	W+5	325.25	329.75	371	40	627.25	631.75	673	
	W+6	331.25	335.75	377	41	633.25	637.75	679	
W+7	337.25	341.75	383	42	639.25	643.75	685		
W+8	343.25	347.75	389	43	645.25	649.75	691		
W+9	349.25	353.75	395	44	651.25	655.75	697		
W+10	355.25	359.75	401	45	657.25	661.75	703		

USA CHANNEL FREQUENCY TABLE (181 CH)

P IF=45.75 MHz

C IF=42.17MHz

S IF=41.25MHz

UNIT: MHz

BAND	CHANNEL	P CARRIER	S CARRIER	LOCAL
UHF	46	663.25	667.75	709
	47	669.25	673.75	715
	48	675.25	679.75	721
	49	681.25	685.75	727
	50	687.25	691.75	733
	51	693.25	697.75	739
	52	699.25	703.75	745
	53	705.25	709.75	751
	54	711.25	715.75	757
	55	717.25	721.75	763
	56	723.25	727.75	769
	57	729.25	733.75	775
	58	735.25	739.75	781
	59	741.25	745.75	787
	60	747.25	751.75	793
	61	753.25	757.75	799
	62	759.25	763.75	805
	63	765.25	769.75	811
	64	771.25	775.75	817
	65	777.25	781.75	823
	66	783.25	787.75	829
	67	789.25	793.75	835
	68	795.25	799.75	841
	69	801.25	805.75	847

WIRING DIAGRAM

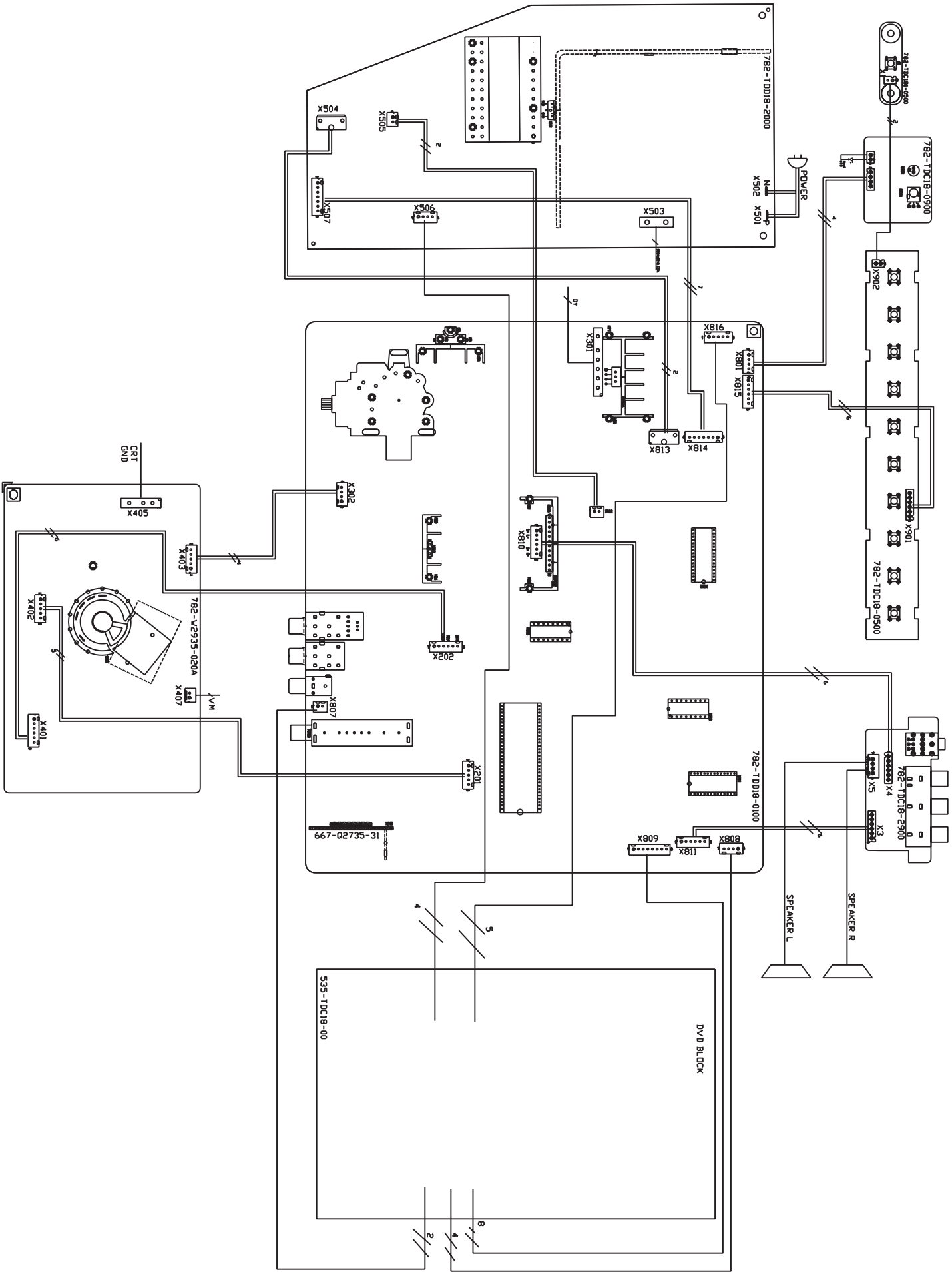

BLOCK DIAGRAM

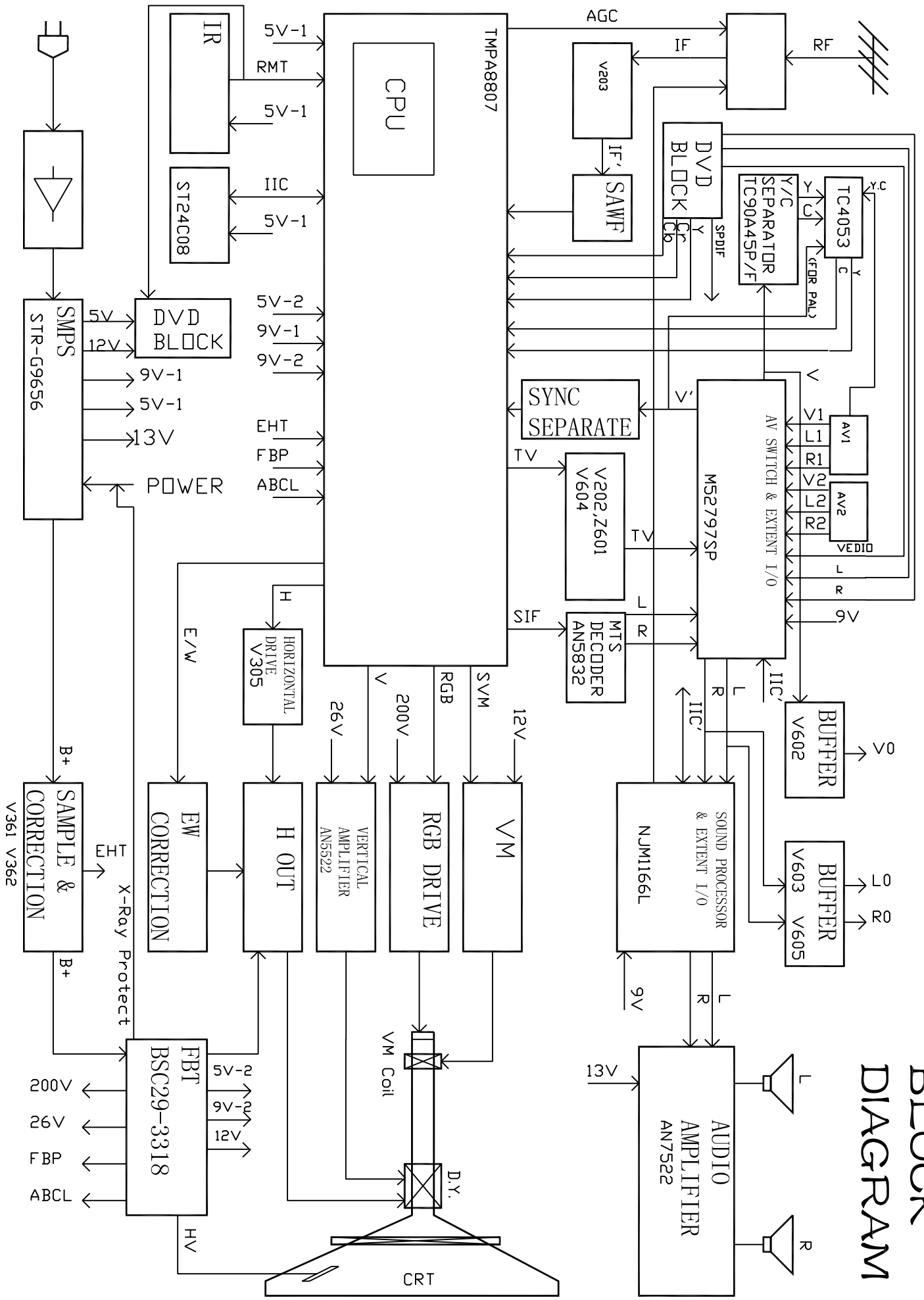

IC BLOCK DIAGRAM

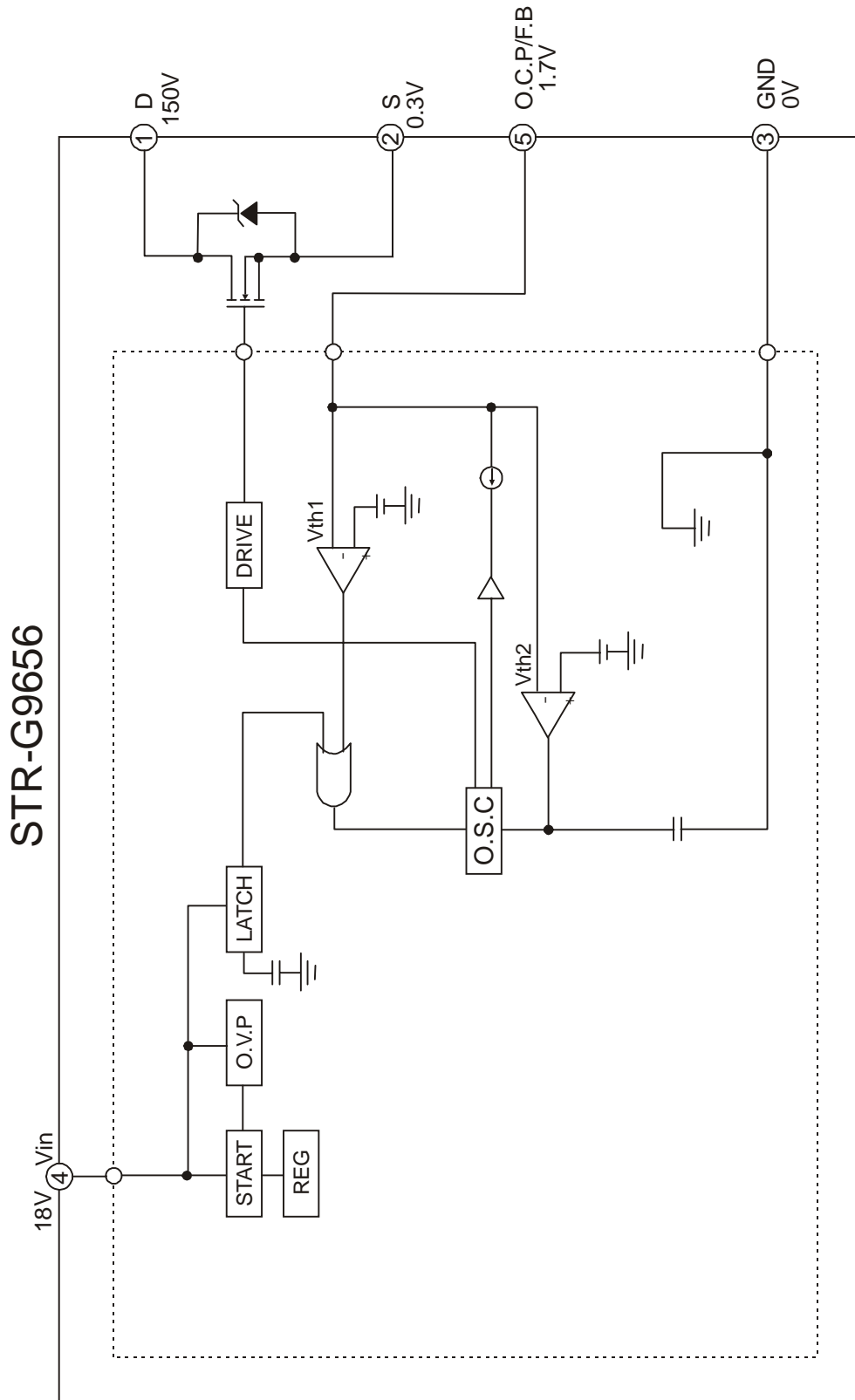

TMPA8807

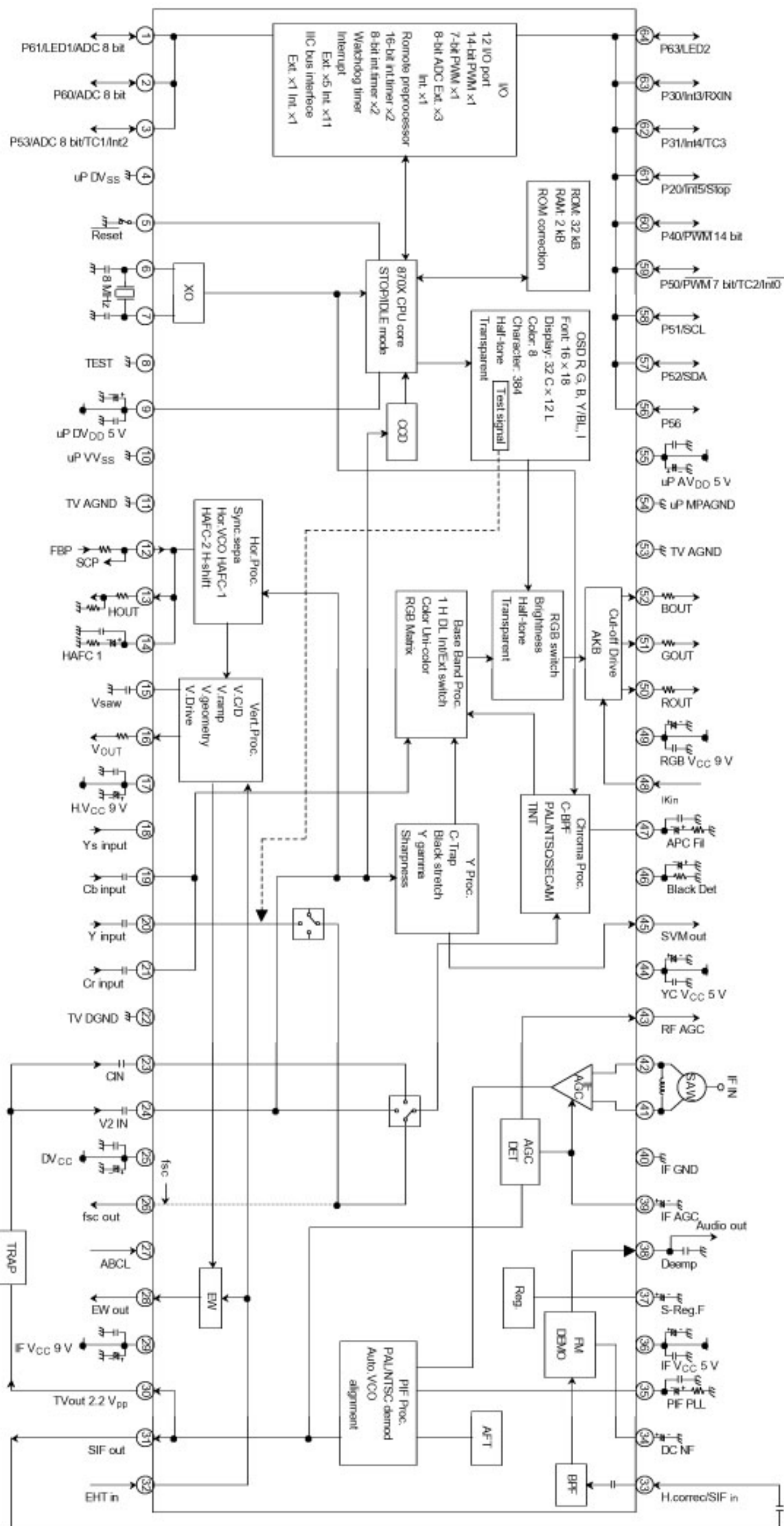

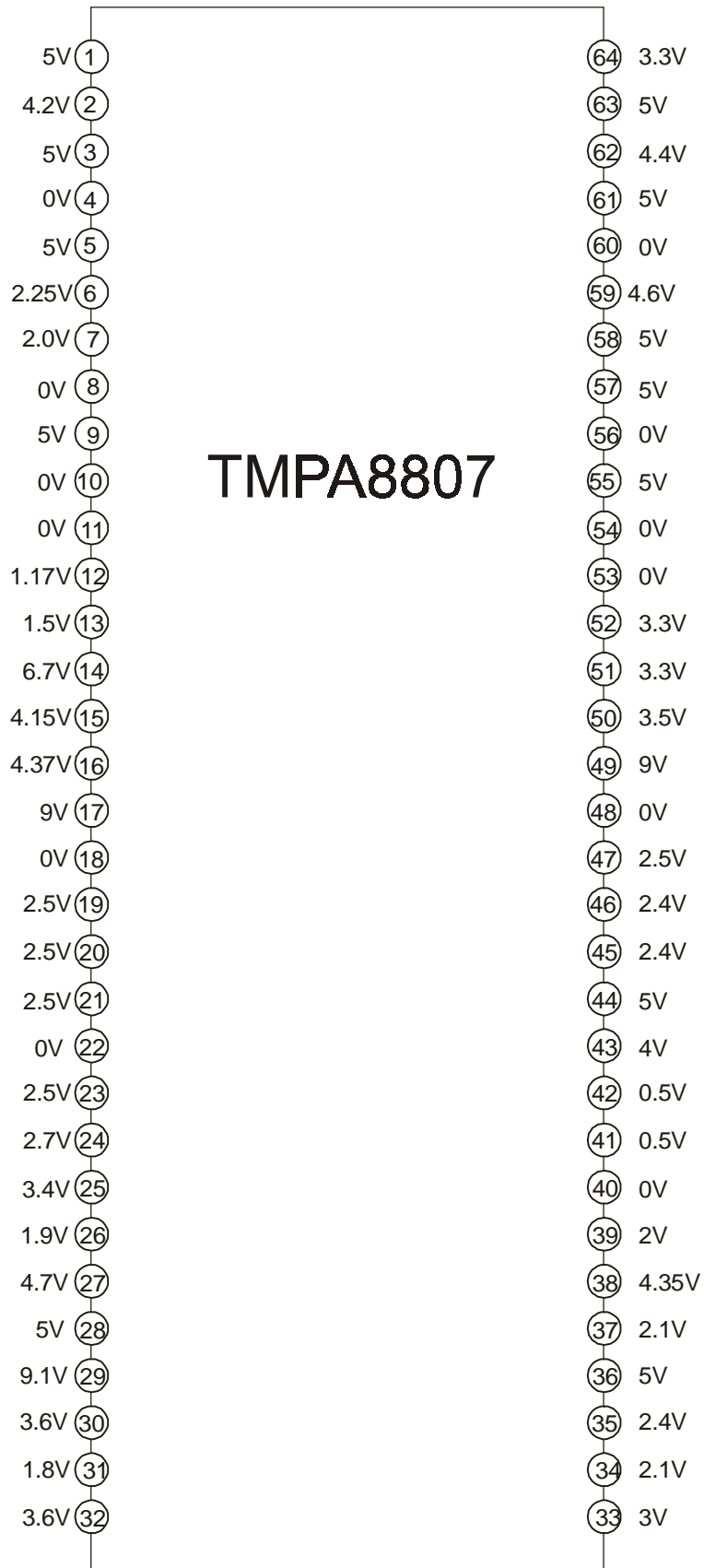

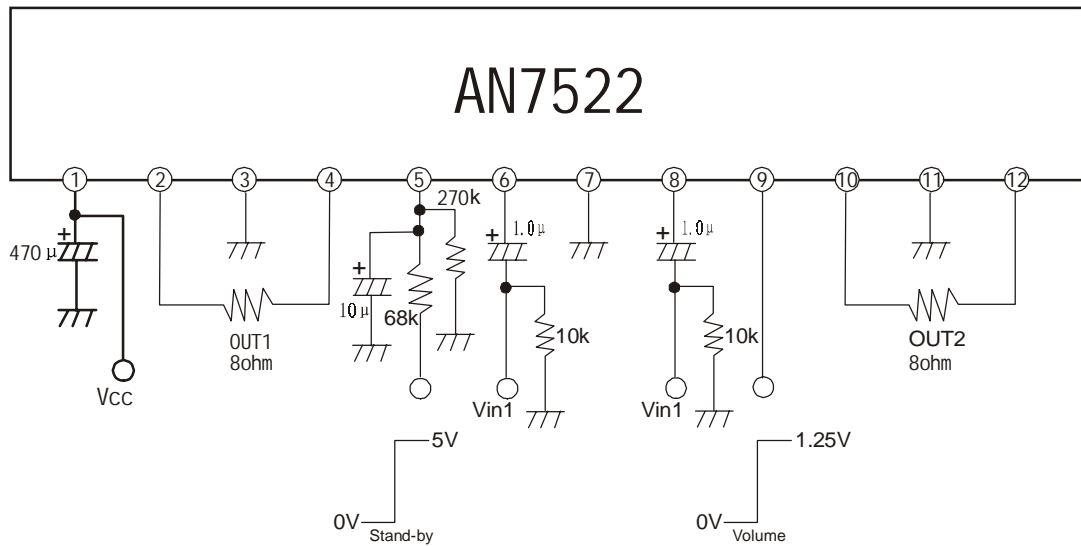

Note: If the standby pin is open or 0V, the IC is on standby state.
 The IC is in the state of volume minimum if the Volume pin is ground.
 The IC is in the state of volume maximum if the Volume pin is open.

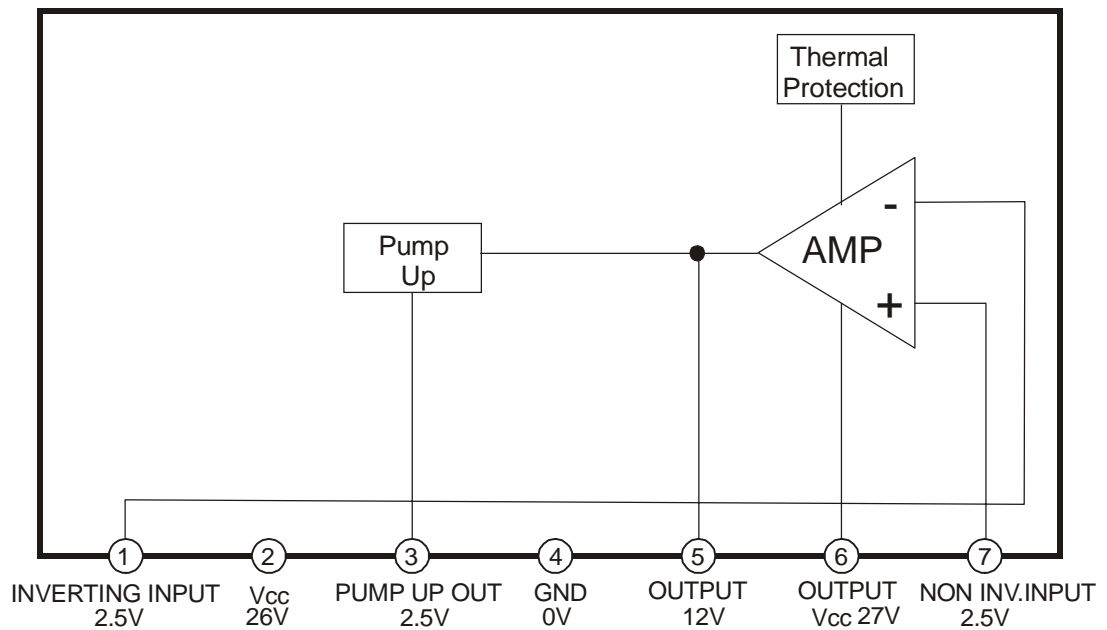

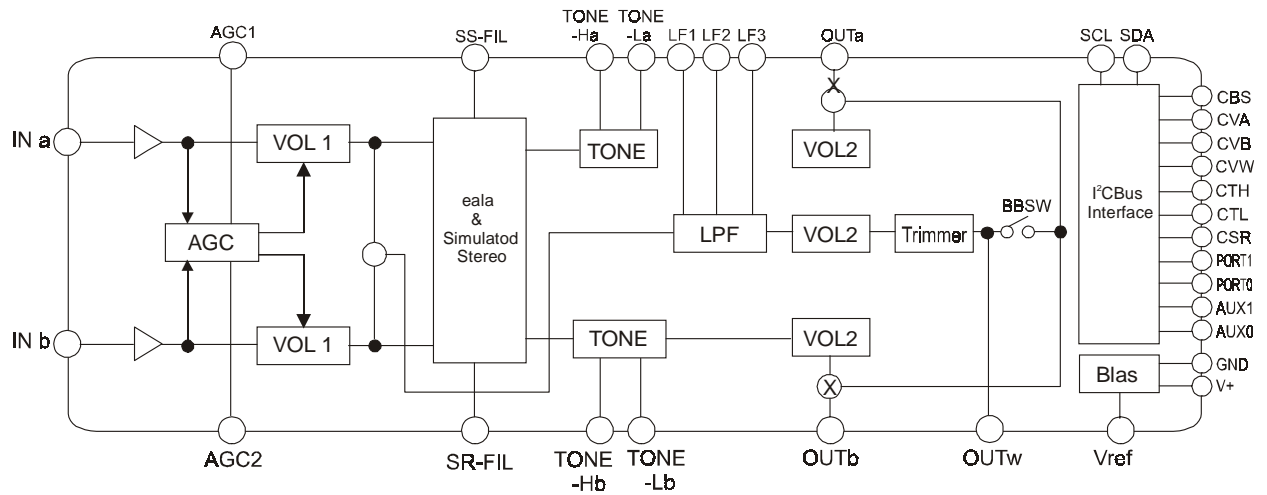

NJW1166

1	AGC	INb	32
2	SR-FIL	LF1	31
3	SS-FIL	LF2	30
4	TONE-Ha	LF3	29
5	TONE-La	TONE-Hb	28
6	OUTW	TONE-Lb	27
7	OUTa	OUTb	26
8	AGC1	AGC2	25
9	AUX0	CVA	24
10	AUX1	CVB	23
11	PORT0	CVW	22
12	PORT1	CTH	21
13	CBS	CTL	20
14	SDA	CSR	19
15	SCL	Vref	18
16	GND	V+	17

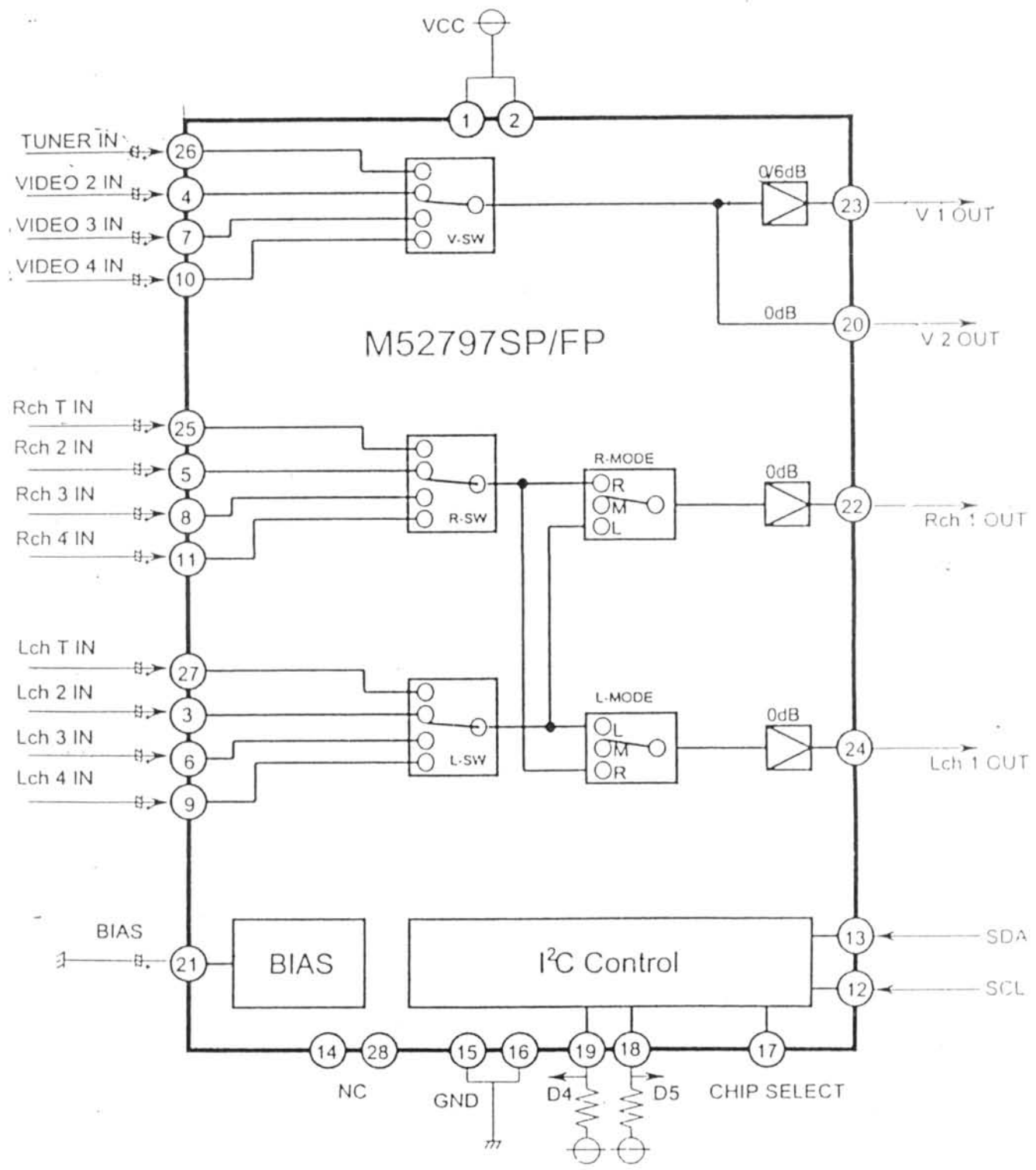

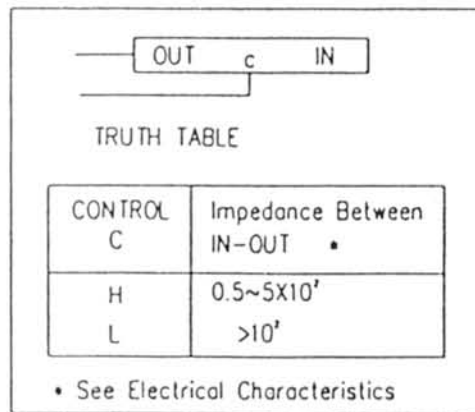
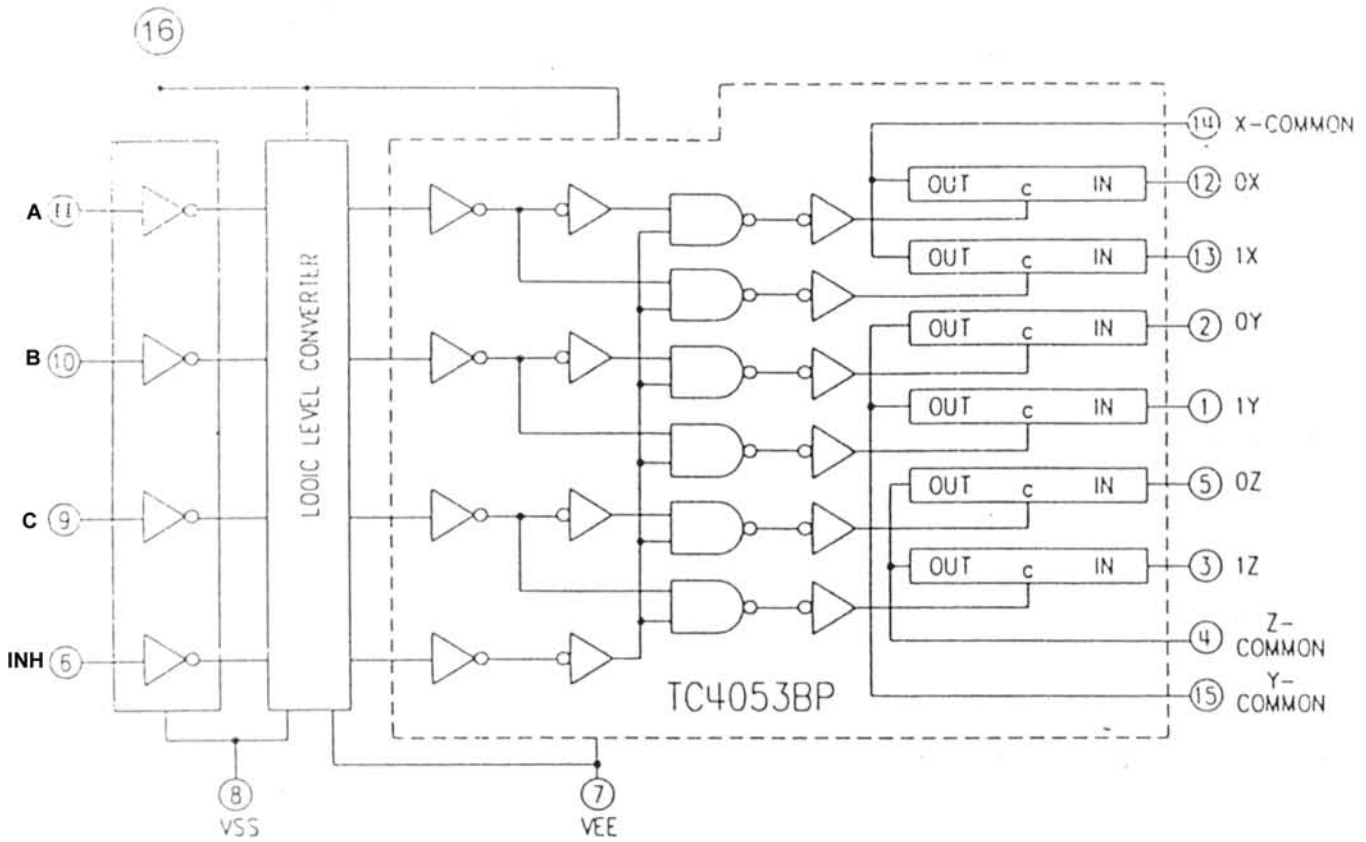

TC90A45P/F

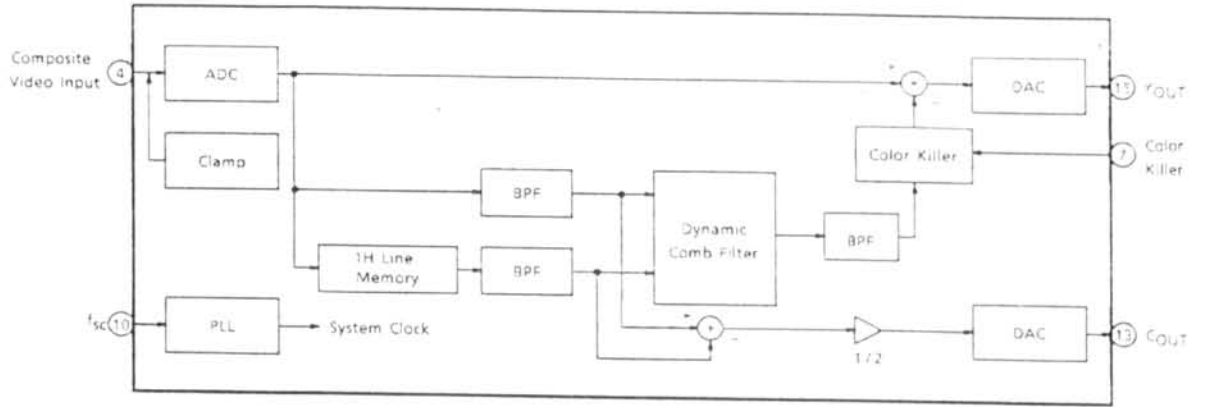

TERMINAL CONNECTION DIAGRAM

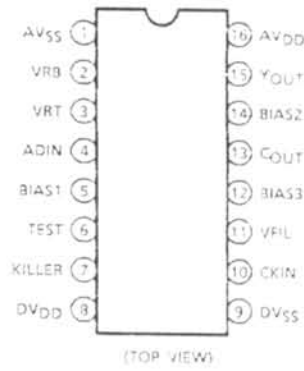

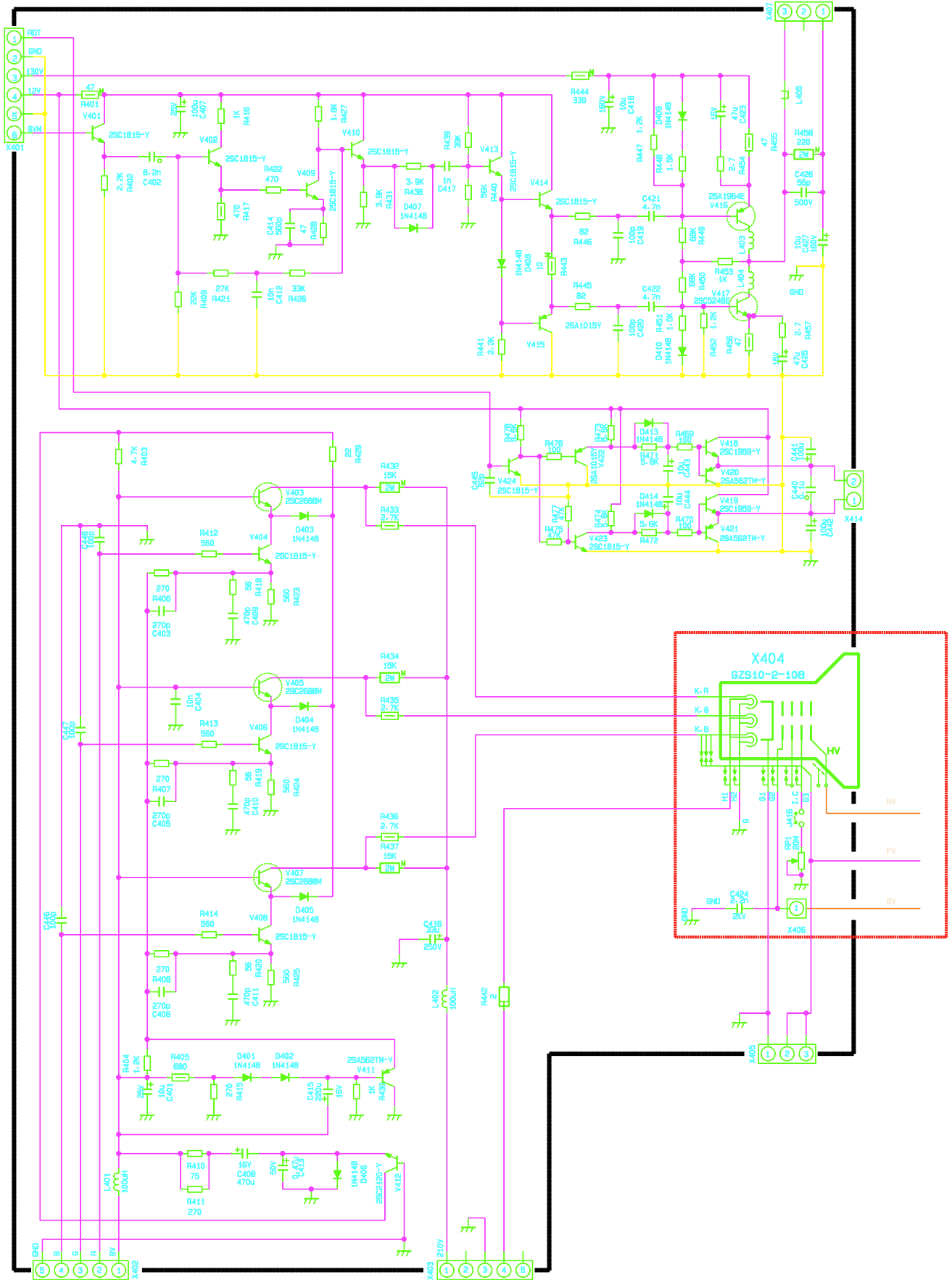

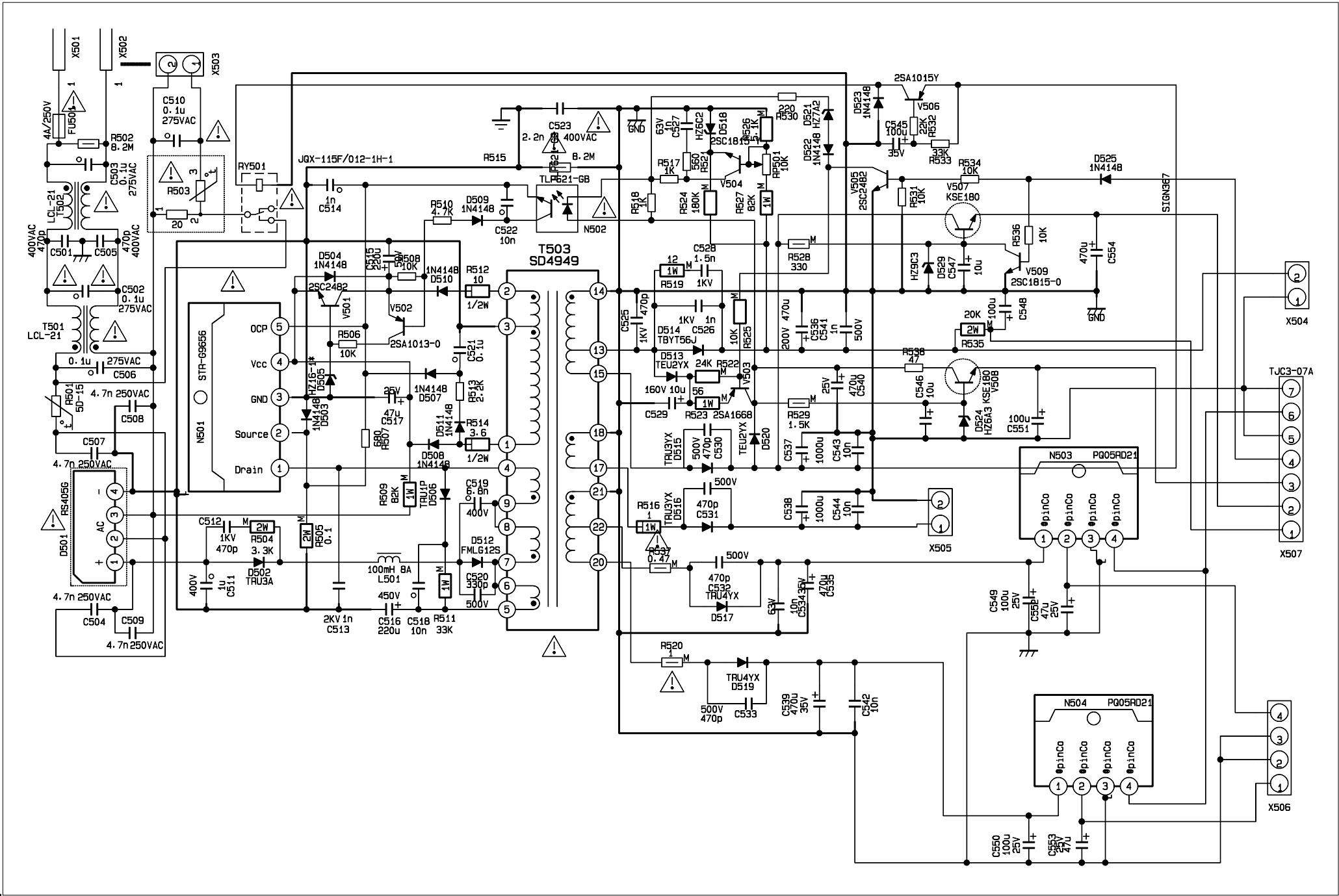

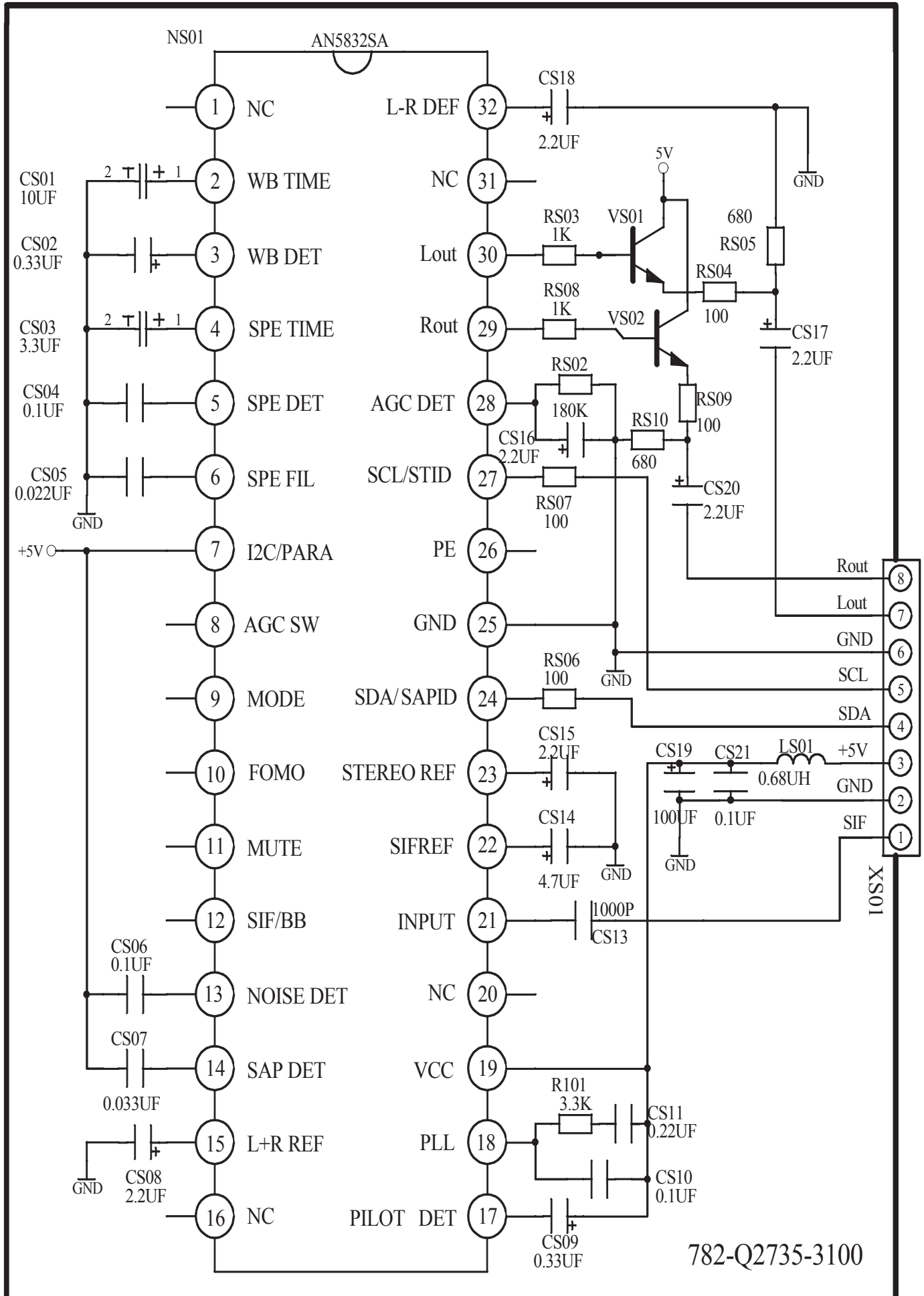

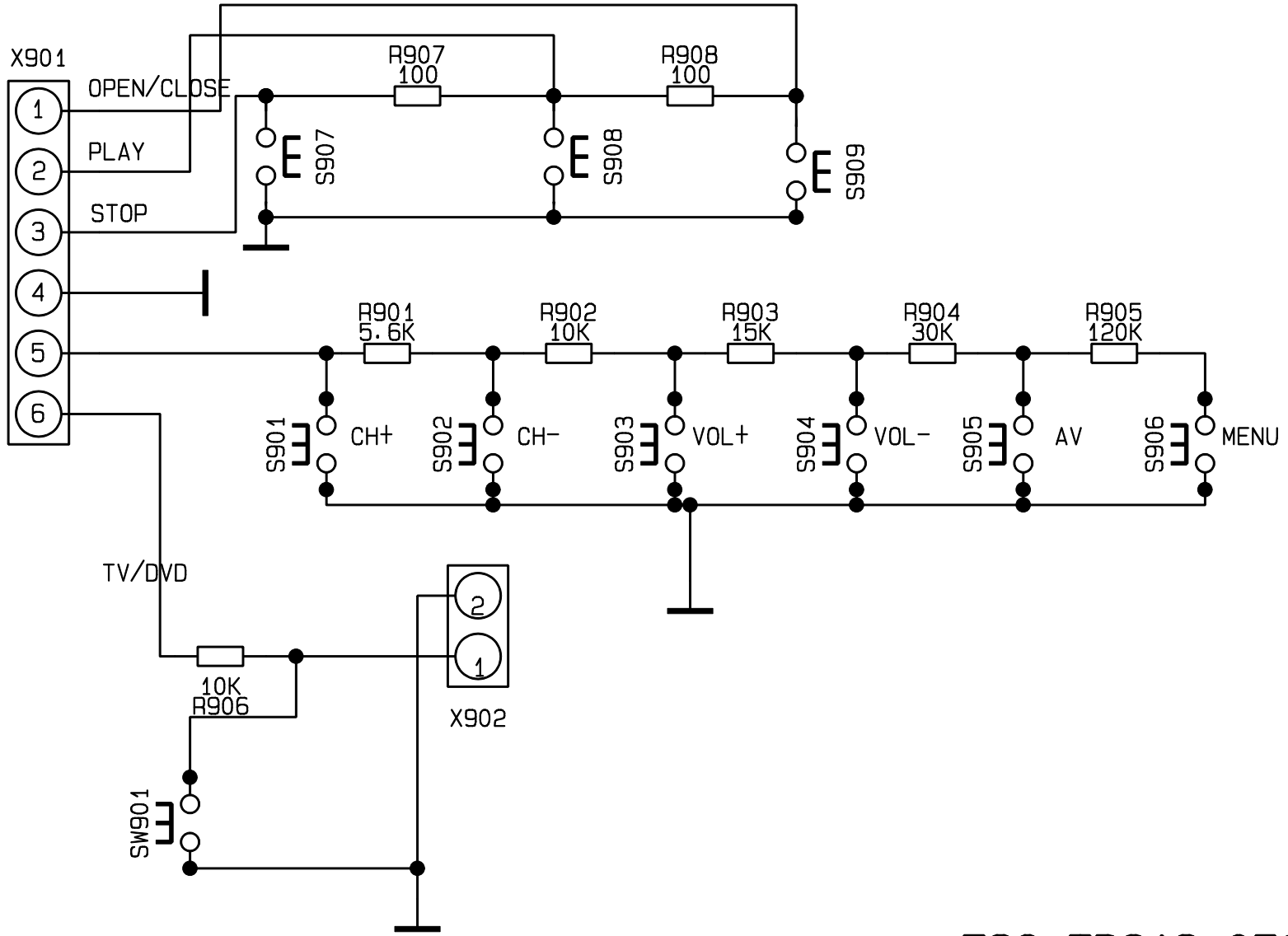

782-TDC18-0500

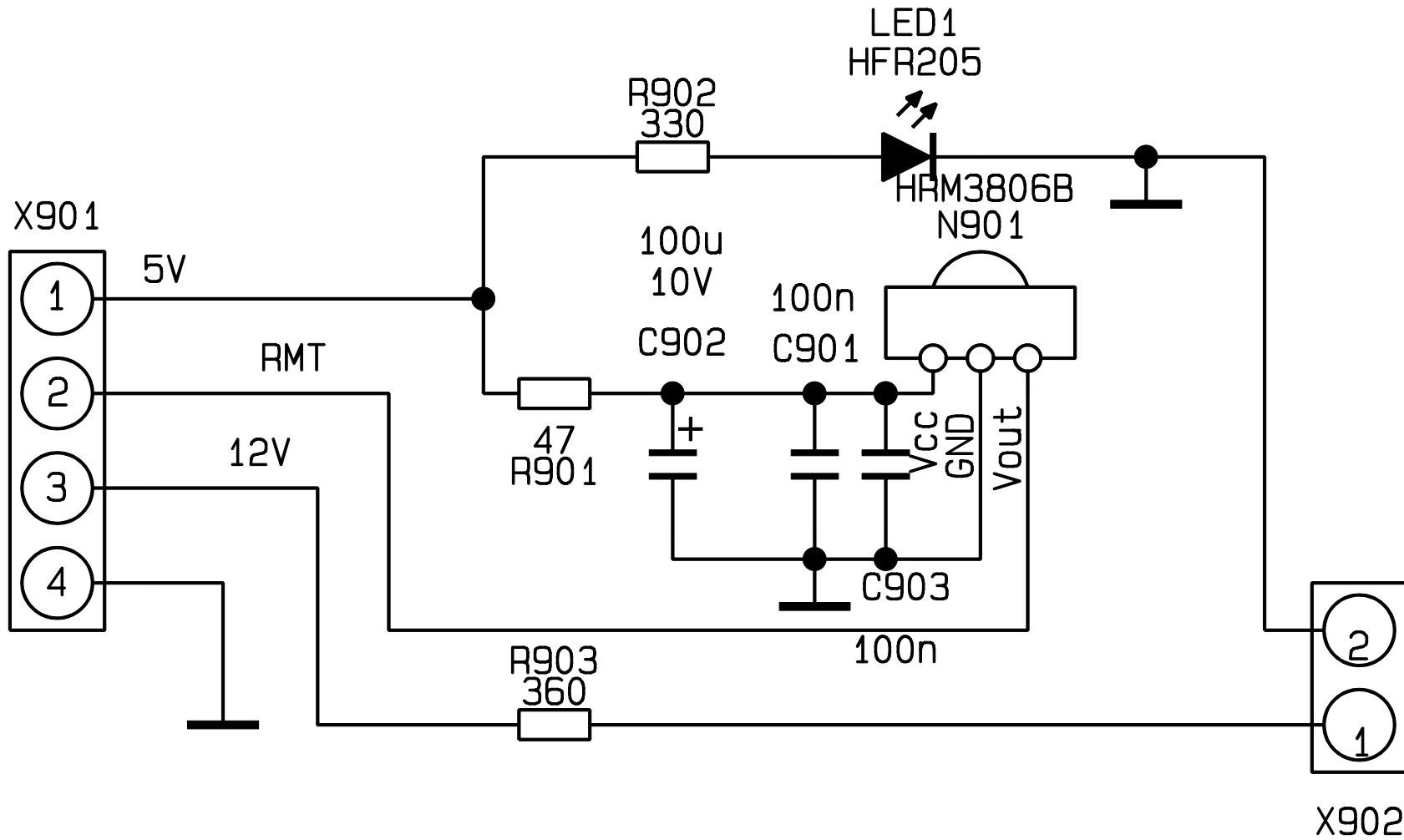

782-TDC18-0900

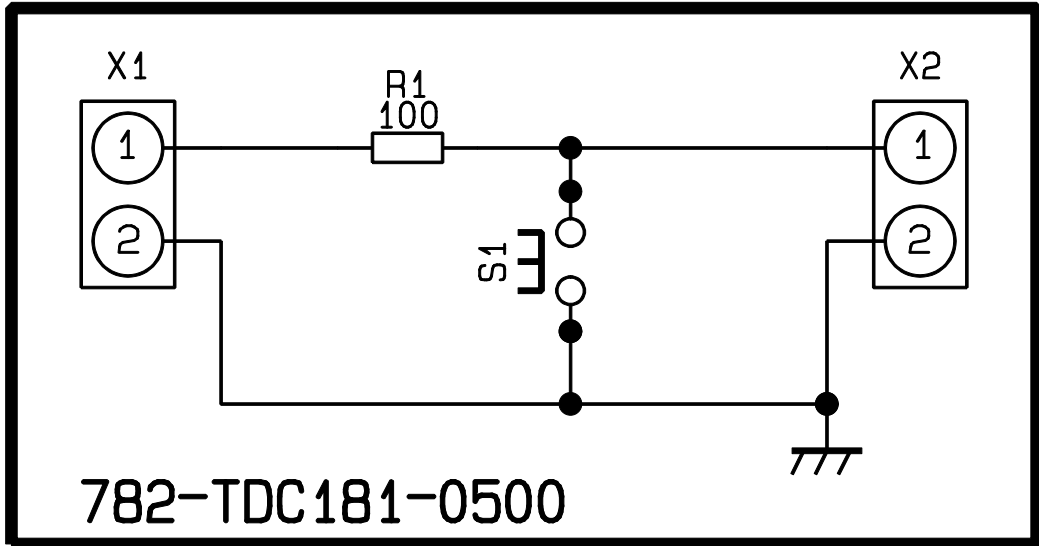

A

B

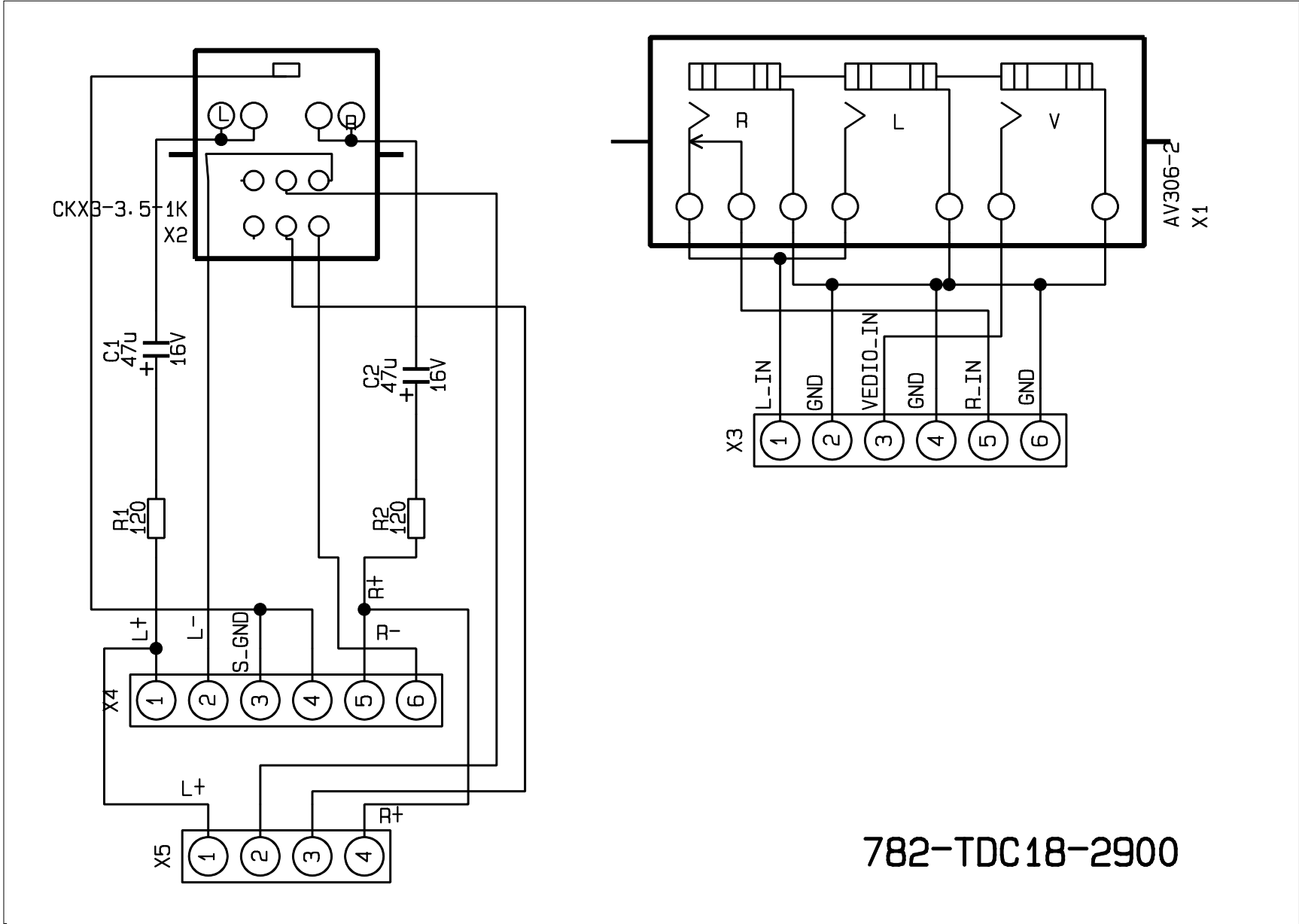

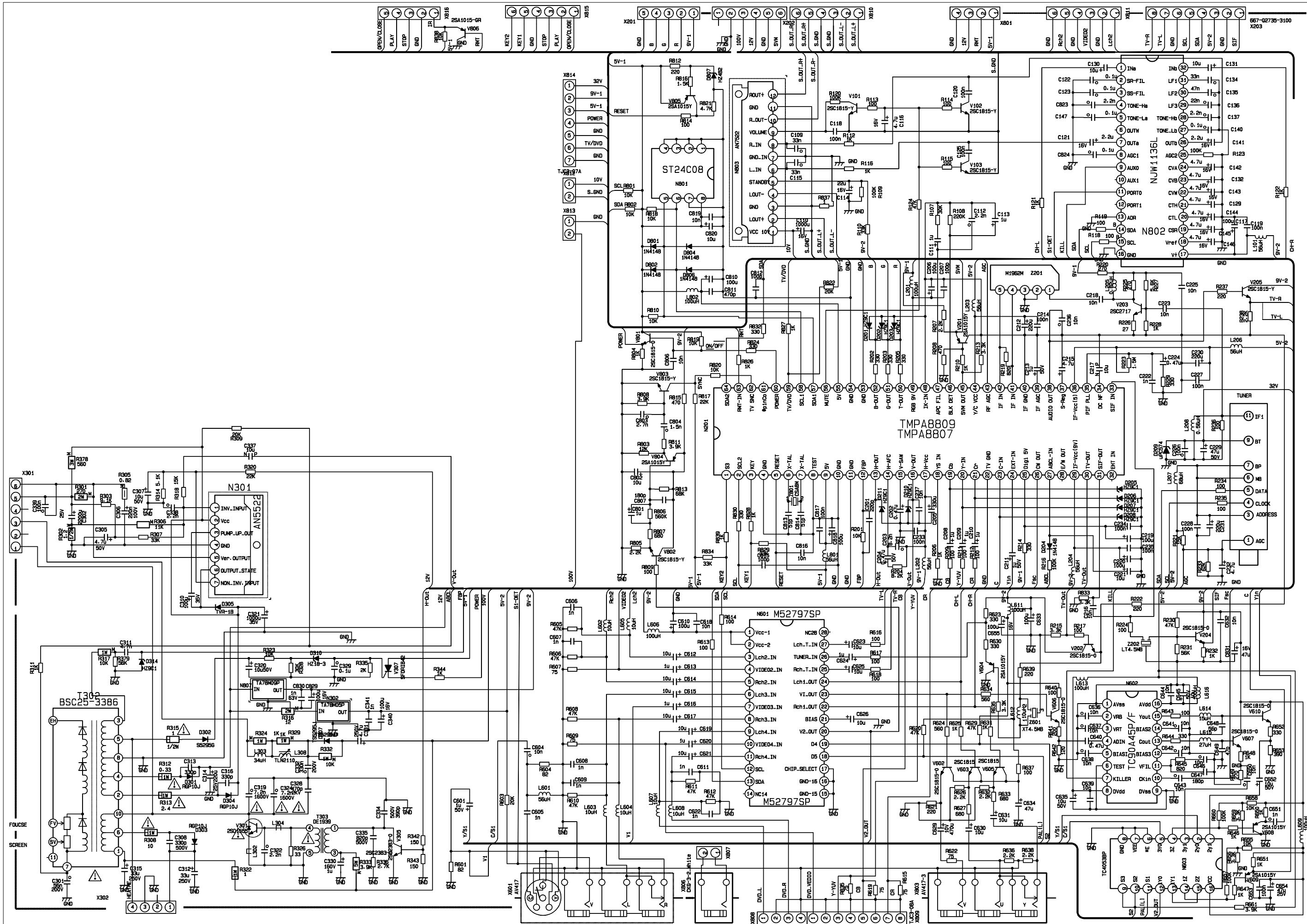

WARNING: BEFORE SERVICING THIS CHASSIS, READ THE “X-RAY RADIATION PERCAUTION”, “SAFETY PRECAUTION” AND “PRODUCT SAFETY NOTICE” ON PAGE 1&2 OF THIS MANUAL.

CAUTION: 1. The shaded areas makes in the schematic diagram and the parts list designate components which have special characteristics important for safety and should be replaced only with type identical to those in the original circuit or specified in the parts list. Before replacing any of these components, read carefully the PRODUCT SAFETY NOTICE on page 2.
2. Do not degrade the safety of the receiver through improper servicing.

ELECTRICAL PARTS LIST

MAIN BOARD

SYMBOL	PART NO.	DESCRIPTION
	782-TDD18-0100	MAIN PCB
DIODE		
D303	340-00014-00	RGP10J
D315	340-00014-00	RGP10J
D313	340-00014-00	RGP10J
D312	340-00070-00	ERD07-15
D806	340-00001-003	1N4148
D804	340-00001-003	1N4148
D802	340-00001-003	1N4148
D801	340-00001-003	1N4148
D204	340-00001-003	1N4148
D309	340-00001-003	1N4148
D307	340-00005-003	S5295J
D302	340-00010-003	S5295G
D301	340-00014-003	RGP10J
D304	340-00014-003	RGP10J
D305	340-00086-003	TVR-1B
REGULATED DIODE		
D311	340-50200-003	HZ2B1
D807	340-50390-003	HZ4B2
D314	340-50910-003	HZ9C1
D207	340-50910-003	HZ9C1
D208	340-50910-003	HZ9C1
D205	340-50910-003	HZ9C1
D206	340-50910-003	HZ9C1
D210	340-50910-003	HZ9C1

SYMBOL	PART NO.	DESCRIPTION
D211	340-50910-003	HZ9C1
D203	340-50910-003	HZ9C1
D202	340-50910-003	HZ9C1
D201	340-50910-003	HZ9C1
D310	340-51850-003	HZ18-3
TRANSISTOR		
V608	343-10150-104	2SA1015Y Pr2.5
V609	343-10150-104	2SA1015Y Pr2.5
V805	343-10150-104	2SA1015Y Pr2.5
V804	343-10150-104	2SA1015Y Pr2.5
V604	343-10150-104	2SA1015Y Pr2.5
V201	343-10150-104	2SA1015Y Pr2.5
V303	343-10150-104	2SA1015Y Pr2.5
V306	343-10150-104	2SA1015Y Pr2.5
V304	343-10150-104	2SA1015Y Pr2.5
V806	343-10150-704	2SA1015GR
V101	343-18150-114	2SC1815-Y
V102	343-18150-114	2SC1815-Y
V103	343-18150-114	2SC1815-Y
V802	343-18150-114	2SC1815-Y
V803	343-18150-114	2SC1815-Y
V205	343-18150-114	2SC1815-Y
V801	343-18150-604	2SC 1815-0
V610	343-18150-604	2SC 1815-0
V204	343-18150-604	2SC 1815-0
V607	343-18150-604	2SC 1815-0
V606	343-18150-604	2SC 1815-0
V202	343-18150-604	2SC 1815-0
V602	343-18150-604	2SC 1815-0
V603	343-18150-604	2SC 1815-0
V605	343-18150-604	2SC 1815-0
V362	343-18150-604	2SC 1815-0
V203	343-27170-004	2SC2717
V307	343-00420-40	SFORIB42
V361	343-13200-00	2SA1320
V305	343-23830-60	2SC2383-0
V301	343-20090-80	ST2009DHI
V302	343-38520-00	2SC3852
CRYSTAL		
Z801	329-58001-00	8MHZ
IC		
D209	352-05740-00	uPC574

SYMBOL	PART NO.	DESCRIPTION
N802	352-11660-10	NJW1166
N801	352-24080-00	ST24C08
N603	352-40530-00	TC4053BP
N601	352-52797-20	M52797SP
N301	352-55220-00	AN5522
N803	352-75220-00	AN7522N
N302	352-78050-40	TA78M05P
N807	352-78090-40	TA78M09P
N201	352-88070-00	TMPA8807PSAN
N602	352-90450-50	TC90A45P
SAW FILTER		
Z201	458-07008-00	M1962M
WIRE-ROUND RESISTOR		
R333	467-B0239-H0	RX25-5W-3.9K-J
R302	467-6FA12-H0	RX21-1-1.2Ω-J
METAL RESISTOR		
R306	467-2D311-F0	1/4W-11K-F
R305	467-2EB82-H0	1/2W-0.82Ω-JL
R339	467-2F351-H0	1W-51kΩ-JL
R329	467-2F210-H0	1W-1KΩ-JL
R324	467-2F210-H0	1W-1KΩ-JL
R332	467-2F310-H0	1W-10kΩ-JL
R317	467-2F310-H0	1W-10kΩ-JL
R341	467-2GA56-H0	2W-5.6Ω-JL
R316	467-2G012-H0	2W-12Ω-JL
R301	467-2G127-H0	2W-270Ω-JL
MELTABLE RESISTOR		
R315	467-4E001-H0	1/2W-1Ω-JL
R312	467-4FB33-H0	1W-0.33Ω-JL
R322	467-4F001-H0	1W-1Ω-JL
R313	467-4F001-H0	1W-1Ω-JL
R308	467-4F010-H0	1W-10Ω-JL
INDUCTANCE WITH COLOUR CODES		
L208	471-2B56K-003	SPT0305-R56K-5
L205	471-2B82K-003	SPT0305-R82K-5
L207	471-2068K-003	SPT0305-680K-5
L611	471-2110K-003	SPT0305-101K-5
L203	471-1056K-00	EL0606SK1-560K
L612	471-2010K-A0	SP0203-10uH-K
L605	471-2010K-A0	SP0203-10uH-K
L602	471-2010K-A0	SP0203-10uH-K
L603	471-2010K-00	SPT0305-100K-5

SYMBOL	PART NO.	DESCRIPTION
L604	471-2010K-00	SPT0305-100K-5
L607	471-2010K-00	SPT0305-100K-5
L608	471-2010K-00	SPT0305-100K-5
L614	471-2015K-A0	SP0203-15uH-K
L615	471-2027K-A0	SP0203-27uH-K
L202	471-2056H-60	LGA0307-56uH-J
L101	471-2056H-60	LGA0307-56uH-J
L801	471-2056H-60	LGA0307-56uH-J
L204	471-2056H-60	LGA0307-56uH-J
L206	471-2056H-60	LGA0307-56uH-J
L601	471-2056K-00	SPT0305-560K-5
L616	471-2110K-A0	SP0203-100uH-K
L613	471-2110K-A0	SP0203-100uH-K
J208	471-2110K-A0	SP0203-100uH-K
L802	471-2110K-A0	SP0203-100uH-K
L201	471-2110K-A0	SP0203-100uH-K
L609	471-2110K-A0	SP0203-100uH-K
L606	471-2110K-00	SPT0305-101K-5
CEMENT RESISTOR		
R370	467-50A56-H0	RX27-1-5-5.6Ω-J !
FIXED INDUCTANCE		
L305	477-40128-00	LE1940
H-DRIVE TRANSFORMER		
T303	472-10001-00	XR0961
CERAMIC FILTER		
Z202	475-15451-00	LT4.5MH
CERAMIC TRAP FILTER		
Z601	475-25451-00	XT4.5MB
H-LINEARITY COIL		
L303	477-00065-00	HL1830H-X13
FBT		
T302	472-25117-00	BSC29-3318 !
OTHER		
TUNER	590-40707-00	115-B-8035AZ
DEGAUSSING COIL	477-12501-00	BD-205-7 !
POWER CORD	491-7521D-02	UL !
CRT	335-2512S-00	A60CPAA00X02 !

CRT BOARD

SYMBOL	PART NO.	DESCRIPTION
	782-W2935-0200	CRTPCB
TRANSISTOR		
V411	343-05620-10	2SA562TM-Y
V415	343-10150-10	2SA1015Y
V401	343-18150-11	2SC1815-Y
V402	343-18150-11	2SC1815-Y
V404	343-18150-11	2SC1815-Y
V406	343-18150-11	2SC1815-Y
V408	343-18150-11	2SC1815-Y
V409	343-18150-11	2SC1815-Y
V410	343-18150-11	2SC1815-Y
V413	343-18150-11	2SC1815-Y
V414	343-18150-11	2SC1815-Y
V416	343-19640-30	2SA1964E
V403	343-26880-60	2SC2688M
V405	343-26880-60	2SC2688M
V407	343-26880-60	2SC2688M
V417	343-52480-30	2SC5248E
CRT SOCKET		
X404	364-58210-00	GZS10-2-102G !
METAL RESISTOR		
R443	467-2E010-H0	1/2W-10Ω-JL
R401	467-2E047-H0	1/2W-47Ω-JL
R444	467-2E133-H0	1/2W-330Ω-JL
R458	467-2F122-H0	1W-220Ω-JL
R432	467-2G312-H0	2W-12kΩ-JL
R434	467-2G312-H0	2W-12kΩ-JL
R437	467-2G312-H0	2W-12kΩ-JL
CARBON RESISTOR		
R433	467-8E227-H1A	1/2W-2.7KΩ-J !
R435	467-8E227-H1A	1/2W-2.7KΩ-J !
R436	467-8E227-H1A	1/2W-2.7KΩ-J !
INDUCTANCE WITH COLOUR CODES		
L401	471-1056H-00	EL0606SKI-560J
L402	471-2110K-00	SPT0305-101K-5
DIODE		
D401	340-00001-00	1N4148
D402	340-00001-00	1N4148
D403	340-00001-00	1N4148
D404	340-00001-00	1N4148

SYMBOL	PART NO.	DESCRIPTION
D405	340-00001-00	1N4148
D407	340-00001-00	1N4148
D408	340-00001-00	1N4148
D409	340-00001-00	1N4148
D410	340-00001-00	1N4148

INFRARED SENSOR BOARD

SYMBOL	PART NO.	DESCRIPTION
	782-TDC18-0900	INFRARED SENSOR PCB
LIGHT-EMITTING DIODE		
LED1	340-10039-20	HFR205 (RED)
IC		
N901	352-03810-80	AT138B-T12

EXPLODED VIEW

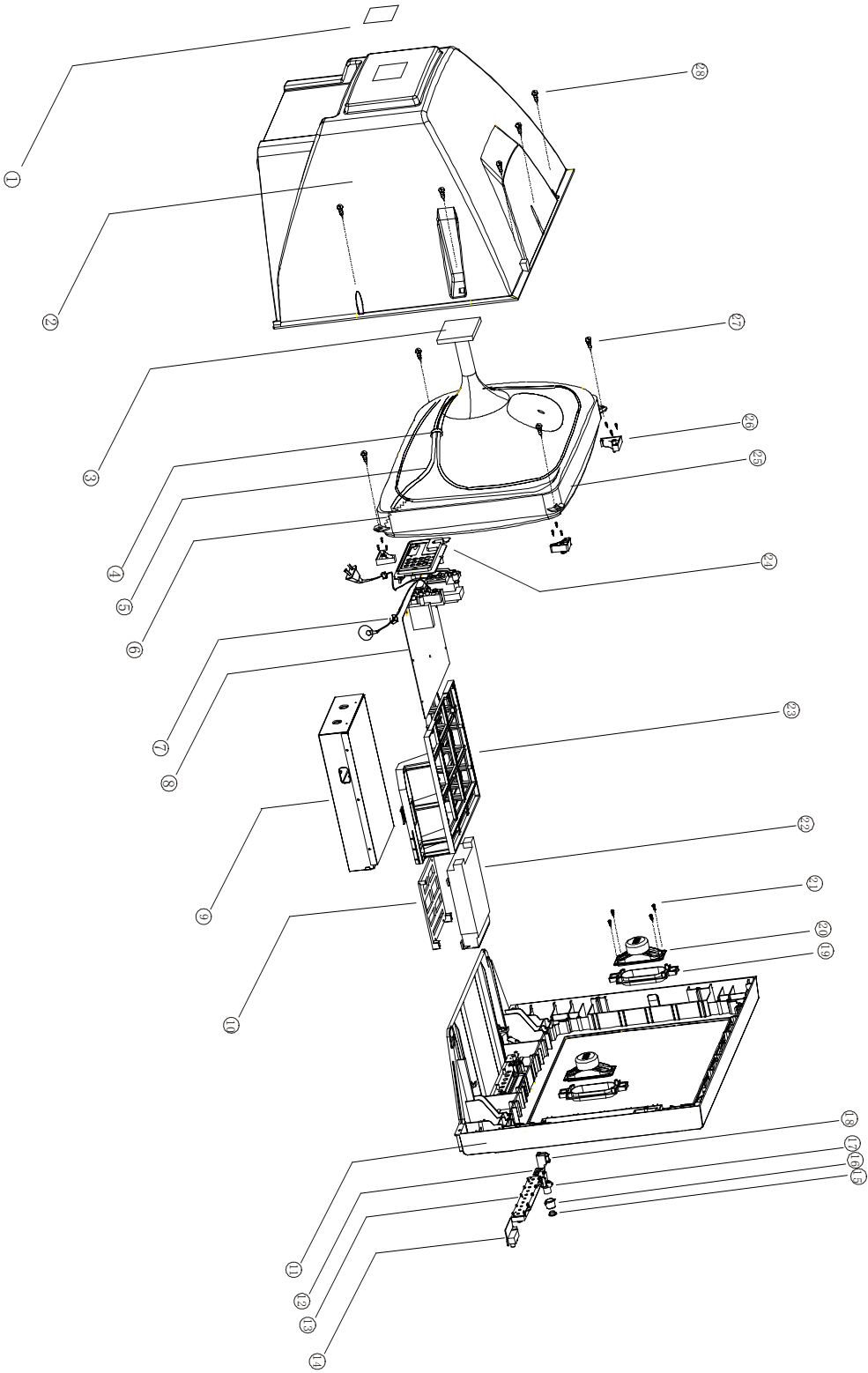

PARTS LIST OF EXPLODED VIEW

NO.	NAME	PART NO.	NO.	NAME	PART NO.
1	LABEL	880-10205	16	LIGHT-LEADING CIRCLE	700-60168-00
2	BACK CABINET	780-D18CH-00	17	LIGHT-TOUCH BUTTON BRACKET	870-30003-00
3	CRT BOARD ASSEMBLY	667-TDD18-12	18	POWER SWITCH	360-30028-00
4	THREAD CLASP	742-30005-0P	19	SPEAKER BRACKET	870-20849-00
5	DEGAUSSING COIL	477-12501-00	20	SPEAKER	384-40308-40
6	BRAIDED PULLING SPRING	838-10012-00	21	SCREW	851-53012-11
7	POWER THREAD CLASP	862-20028-00	22	DVD MECHANISM	535-TD2018-00
8	MAIN BOARD ASSEMBLY	667-TDD18-01	23	MAIN FRAME	863-60150-00
9	SHIELDING COVER	859-11236-00	24	REAR PANEL	808-10611-00
10	DVD BRACKET	870-30001-00	25	CRT	335-2512S-00U
11	FRONT CABINET	780-10996-00	26	CRT FIX BOARD ASSEMBLY	615-10105-00
12	LED COLUMN	700-60167-00	27	SCREW	855-A0029-00
13	BUTTON BOARD ASSEMBLY	667-TDC18-05	28	SCREW	851-24020-11
14	FRONT AV	364-93202-00			
15	POWER BUTTON	877-60590-00			